

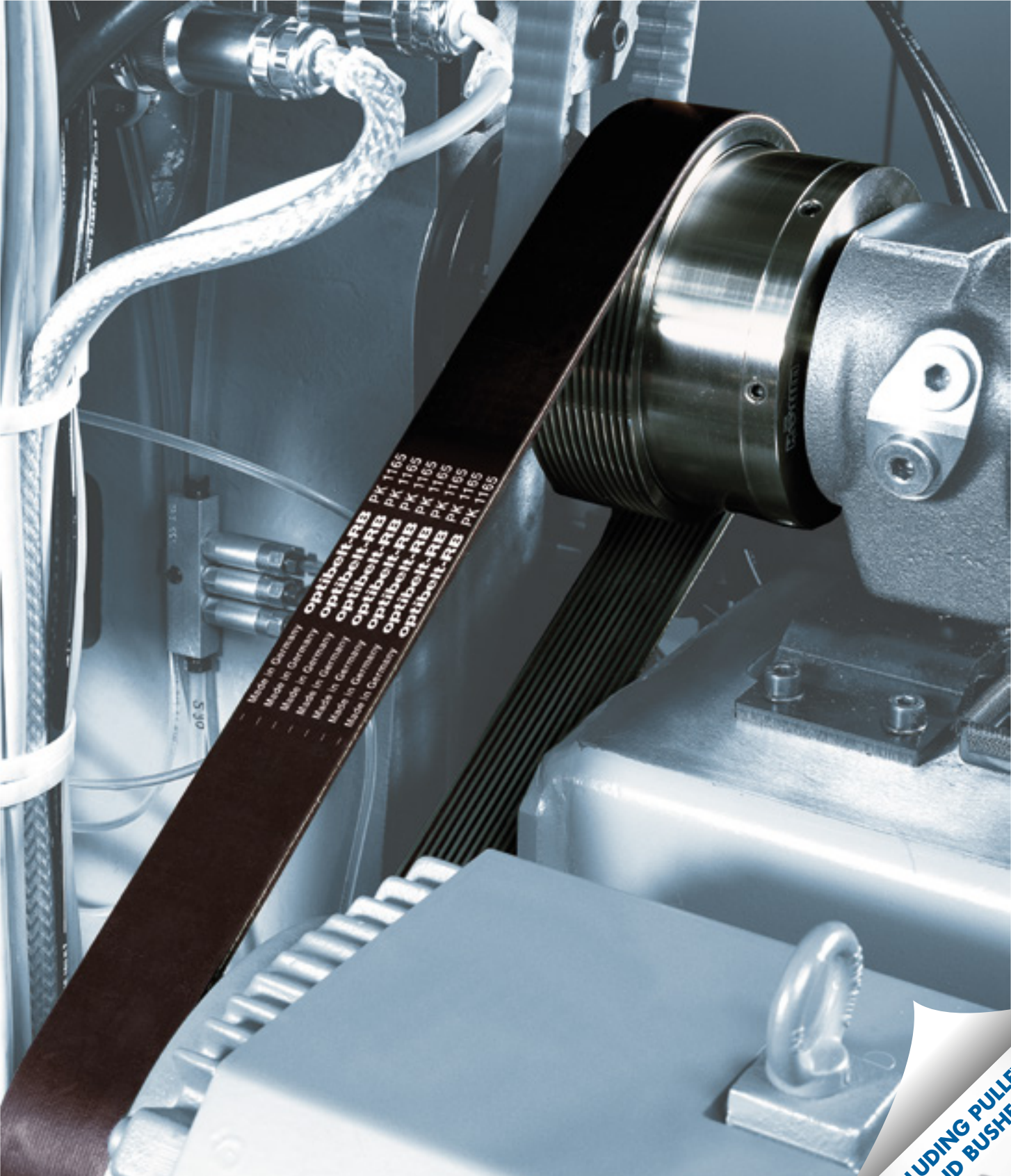

OPTIBELT
TECHNICAL MANUAL
RIBBED BELT DRIVES



**INCLUDING PULLEYS
AND BUSHES**



This manual contains all relevant technical information as well as the method for calculating drives with optibelt RB ribbed belts and optibelt RBS ribbed belt pulleys for mechanical engineering. The Optibelt range for ribbed belt drives is based on the standards ISO 9982, RMA/MPTA IP-26 and DIN 7867.

Our applications engineers would be pleased to give advice about using these drive systems and will work together with you to solve your drive problems. This service is of course free of charge.

It is especially important for large-scale series to take advantage of this service which will find the best possible solution for your requirements using state-of-the-art computer programs.

CONTENTS



	Introduction	1
	Distribution Organisation of the Arntz Optibelt Group	2
	Ribbed Belts and Ribbed Belt Pulleys	4
PRODUCT DESCRIPTION		
	Standard Range optibelt RB Ribbed Belts.....	7
	Elastic optibelt ERB Ribbed Belts / Special Designs	8
	Characteristics – Application Areas	
	Elastic optibelt ERB Ribbed Belts / Roller Conveyor	9
	Special Designs	10-11
	Automotive Drives optibelt CAR POWER RBK	12
STANDARD RANGE		
	Ribbed Belts	13-14
DRIVE DESIGN		
	Abbreviations Used in Formulae	15
	Optibelt Power Rating P_N – Arc of Contact Correction Factor c_1	16
	Belt Length Correction Factor c_3	17-18
	Minimum Allowance x/y above and below Drive Centre Distance a_{nom}	19
	Drive Service Factor c_2	20
	A Guide to Selecting Ribbed Belt Profiles	21
	Formulae and Calculation Example	22-24
	Drive Design – optibelt CAP	25
POWER RATINGS		
	optibelt RB Ribbed Belts, Profile PH	26
	optibelt RB Ribbed Belts, Profile PJ	27
	optibelt RB Ribbed Belts, Profile PK	28
	optibelt RB Ribbed Belts, Profile PL	29
	optibelt RB Ribbed Belts, Profile PM	30



SPECIAL DRIVES

V-Flat Drives	31-32
Tension/Guide Idlers	33-34

RIBBED BELT PULLEYS

Measuring Pulleys – Length Measuring Conditions to DIN 7867/ISO 9982	35
Dimensions to DIN 7867 / ISO 9982	36
Standard Range optibelt TB Taper Bushes	37
Ribbed Belt Pulleys for Taper Bushes, Profile PJ	38-41
Ribbed Belt Pulleys for Taper Bushes, Profile PL	42-46
Ribbed Belt Pulleys for Cylindrical Bore, Profile PJ	47

DESIGN HINTS

Ribbed Belt Tension	48-51
Frequency Meter / Tension Tester optibelt TT	52
Frequency Meter / Tension Tester optibelt TT LINE	53
Determining the Static Shaft Loading / Shaft Loading under Dynamic Conditions	54
Length Tolerances – Installation and Maintenance	55
Ribbed Belt Widths	56
Problems – Causes – Remedies	57-58
Additional Range	
optibelt TT Frequency Meter	59
optibelt LASER POINTER II	59
Optibelt Pulley Groove Gauges	59
Data Sheet for Drive Calculation/Checking	60-61

PRODUCT DESCRIPTION

STANDARD RANGE optibelt RB RIBBED BELTS



Construction

Optibelt ribbed belts consist of:

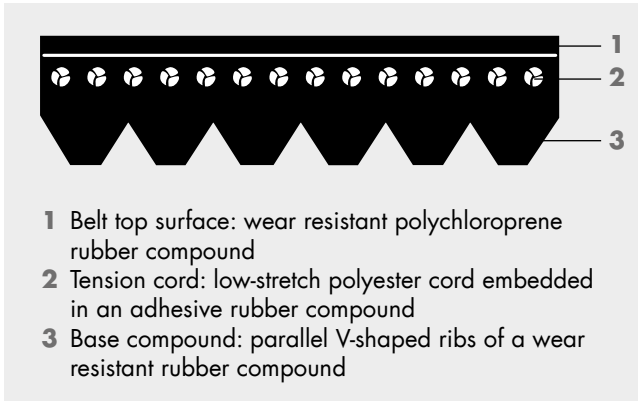

Characteristics

- Combines the high flexibility of the flat belt with the high power transmission capability of the traditional V-belts
- Small pulley diameters
- Large speed ratios possible
- Good frictional power transmission and high power transmission capability
- Insensitive to torque impulses and short-term overloading

Applications

Profile PH

Domestic appliances, medical appliances, machine tools, small conveyors, conveyor belt, paper transport machines

Profile PJ

Small compressors, cement mixers, white goods, small tools

Profile PK

Fans, air conditioning, concrete saws, wood saws, industrial washing machines

Profile PL

Compressors (> 30 kW), industrial washing machines

Profile PM

Paper industry, agricultural machines (silage cutter), sugar cane cutter

Standard Profiles

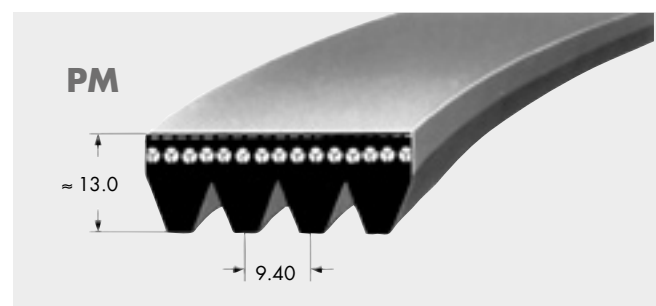
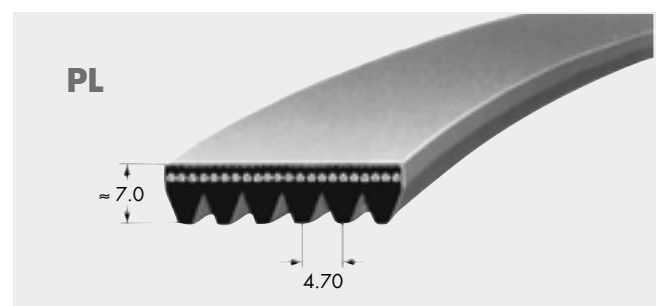
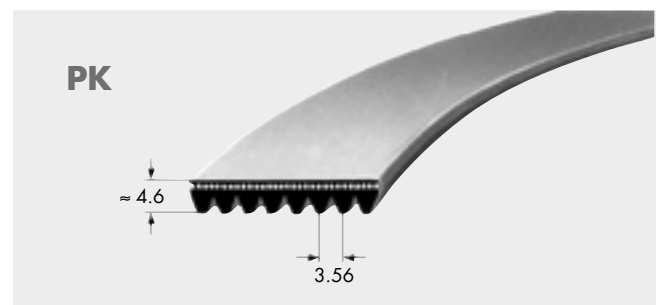
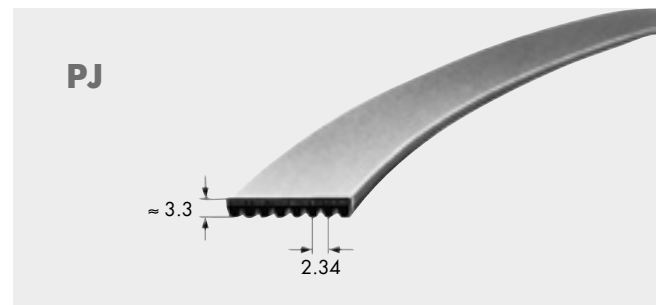
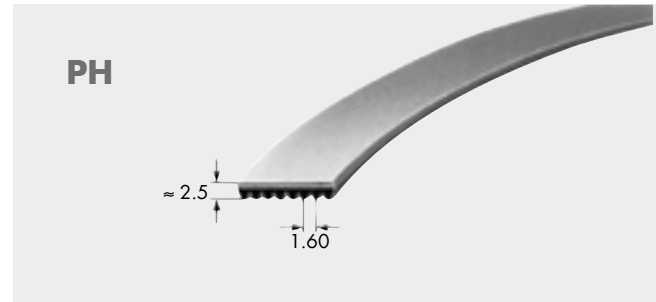

PRODUCT DESCRIPTION

ELASTIC optibelt **ERB** RIBBED BELTS / SPECIAL DESIGNS



Construction

The elastic ribbed belts of profiles EPH, EPJ and EPK consist of:

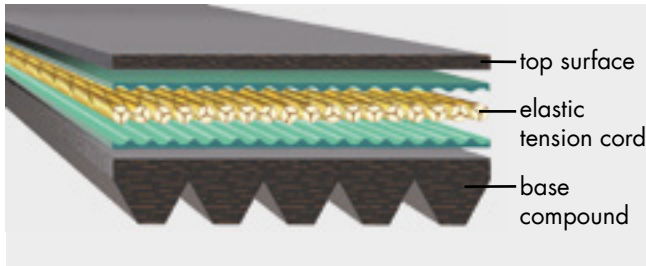

The elastic ribbed belt is characterised by the highly individual options for designing and adapting it for different drive solutions particularly for fixed distances between centres. In addition, the running properties of the ribbed belt can be further optimised by additional refinement of the surface on the ribbed side.

Advantages and Characteristics

- Assembly is possible on fixed centres with no need for adjustment for belt tensioning
- Good damping performance and shock load resistance due to high elasticity of belt
- Maintenance-free and no retensioning required
- Easy assembly in service areas
- Allows individual design of tension and elongation characteristics

Dimensions

Belt lengths depend on the profile, from 250 mm to 2500 mm.

- Ribbed belt – electrically conductive on request
- Ribbed belt – high voltage resistant on request
- PAK optimised – on request

Ribbed Belt Pulleys

Extensive standard range (see range list); special pulleys on request.

Please contact our Applications Engineering Department for individual drive solutions.

Special Versions

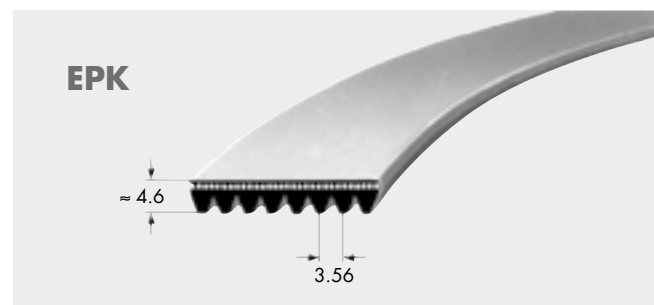
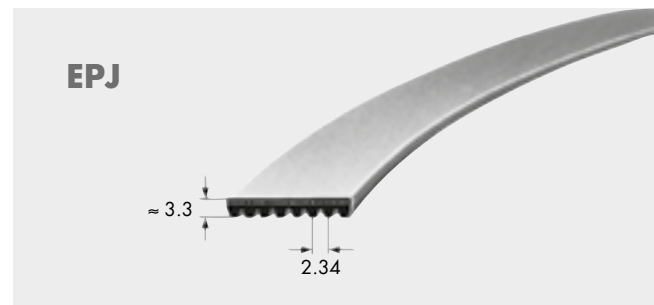
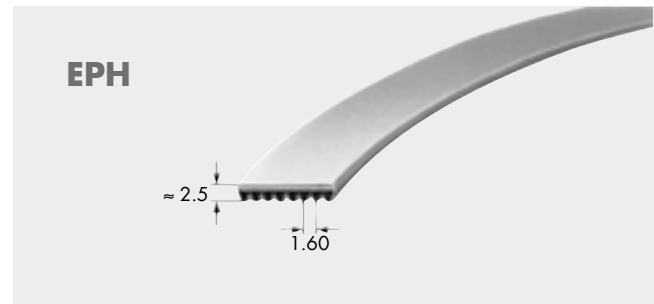

PRODUCT DESCRIPTION

CHARACTERISTICS – APPLICATION AREAS



ELASTIC optibelt **ERB** RIBBED BELTS / ROLLER CONVEYOR

Retensioning Not Necessary – Extended Service Intervals – Optimal Damping of Drive Vibrations

Recently, some roller conveyor belt systems have been equipped with elastic ribbed belts of the model optibelt ERB. Those belts keep the single rolls moving and do not need any retensioning in continuous industrial operation. Thus, they are virtually maintenance-free. For this reason, elastic ribbed belts are now also deployed in transport technology.

The advantages are more than obvious as elastic ribbed belts do not have to be run in in the first place and do not therefore need to be retensioned. optibelt ERB belts gain the required tension due to a higher basic tension and the systematic settling characteristics of the belts. Retensioning can be dispensed with as a result.

Optibelt ribbed belts offer many advantages for end users, too, such as manufacturing companies that use roller conveyor belts as a means of conveyance to the warehouse. Thanks to the belt, the vibrations of the drive are better absorbed, resulting in a smoothly running, extremely low-vibration roller drive. This leads to a minimised wear of the components and extends the operational life of the individual roller bearings. On the other hand, less vibration means less noise and thus improved working conditions.

Given these obvious advantages for users and manufacturers, there is only one definite goal concerning the optimisation of many roller conveyor belt drives: the changeover from round profile belts and timing belts to elastic ribbed belts made by Optibelt.



PRODUCT DESCRIPTION

SPECIAL DESIGNS



PRODUCT DESCRIPTION

SPECIAL DESIGNS

OPTIBELT RIBBED BELTS WITH ARAMID TENSILE REINFORCEMENT

OPTIBELT RIBBED BELTS WITH SPECIAL COATINGS



Ribbed Belts with Aramid Tensile Reinforcement

The extremely low-stretch aramid tension cords stand out in comparison with conventional tensile reinforcement such as polyester. They have almost twice the breaking strength of fibres of the same thickness. Despite their high strength, the fibre is flexible and has sufficient elasticity to cushion shocks and vibrations.

Optibelt ribbed belts with aramid tensile reinforcement are for use where

- maximum power transmission is called for,
- overall widths are restricted,
- minimum adjustment range is available for installation and tensioning and
- high temperature impacts are present.

Ribbed belts with aramid tensile reinforcement are ideal for use in drives with heavy wear in mechanical engineering, special-purpose engineering, agricultural engineering and in garden tools.

It is not possible to go into the entire range of criteria in this manual. Please get in touch with our applications engineers for in-depth advice.

Profiles

PK/PL with 8M or 14M surface

Pulleys

Timing belt pulleys HTD or RPP and ribbed belt pulleys profile PK and PL

Applications

The optibelt OMEGA timing belt with additional ribbed PK belt profile on the back cover of the belt is perfect for use in mills, e.g. food, corn, fruit and flour mills, where the back pulley has a reversible direction and slipping is necessary when the drive blocks.

Advantage

The rubber compound filled with aramid fibres is very wear resistant. The back cover of the PK profile is moulded in one operation with the timing belt.

Optibelt Ribbed Belts with Special Coatings

Due to the huge variety of coatings and finishing possibilities plus the properties of the ribbed belt, Optibelt has developed innovative solutions in the field of conveying technology. Optibelt ribbed belts can be provided with an additional top surface coating. The coating is applied in a special adhesive procedure.

Ribbed belts with a patterned top surface can be used in place of expensive conveyor belts. They run singly or with several belts adjacent to each other and transport the goods to be conveyed horizontally and at up and down gradients. Vertical conveyance is possible if the ribbed belts are arranged back to back and the media conveyed is pressed together between the two belts.

Applications

Examples of some of the many successful uses for Optibelt ribbed belts with coatings include:

- Conveying doors, parts of cabinets, veneer and plastic panels for wood-working
- Conveying car body parts and sharp-edged sheet metal panels in the automotive industry
- Conveying cartons and boxes in the packaging industry

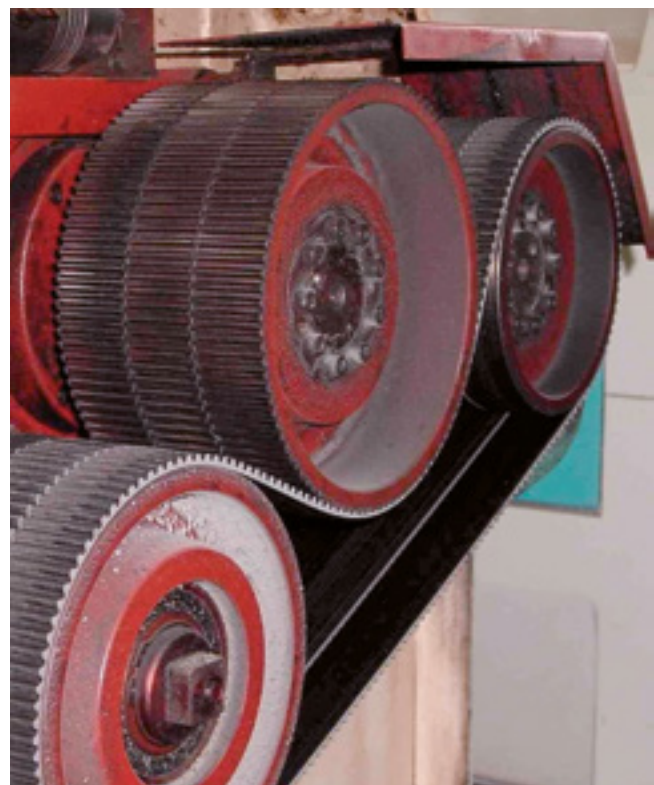
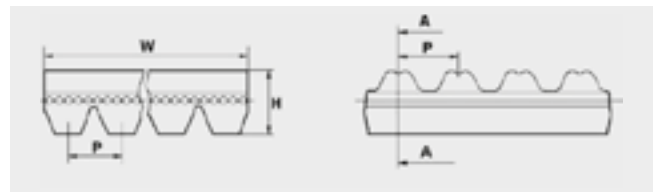

PRODUCT DESCRIPTION

AUTOMOTIVE DRIVES **optibelt** CAR POWER RBK



New engine designs demand more and more space saving. It is not unusual to encounter small pulley diameters and limited drive widths. Being extremely elastic and dimensionally stable, Optibelt ribbed belts can adapt to the respective drive geometry. They are flexible enough to find their path as a serpentine drive through the motor labyrinth. The flexible ribbed belt is extremely quiet and supple in its job of controlling the power train.

Optibelt ribbed belts drive ancillary units in cars, commercial vehicles and buses. They reduce vibration and give the generator, air-conditioning compressor, and the power steering pump the right spin.

Characteristics

- Large speed ratios
- High power transmission
- Minimum slip
- Largely oil and temperature resistant
- Vibration free and quiet
- Extraordinarily resilient

Profiles

PJ, PK, DPK

Dimensions

2 PK	from 786 to 905 mm
3 PK	from 550 to 1285 mm
4 PK	from 560 to 1520 mm
5 PK	from 625 to 2055 mm
6 PK	from 675 to 2680 mm
7 PK	from 870 to 2355 mm
8 PK	from 800 to 2605 mm
9 PK	from 1200 to 4145 mm
10 PK	from 1108 to 2063 mm
11 PK	from 1515 to 2055 mm
12 PK	from 1165 to 2500 mm
3 EPK	from 806 to 885 mm
4 EPK	from 711 to 1102 mm
5 EPK	from 690 to 926 mm
6 EPK	from 691 to 1873 mm
6 DPK	from 1188 to 1853 mm
7 DPK	from 1360 to 1400 mm

Additional sizes on request.

Applications

Use in automotive engineering to drive the power train

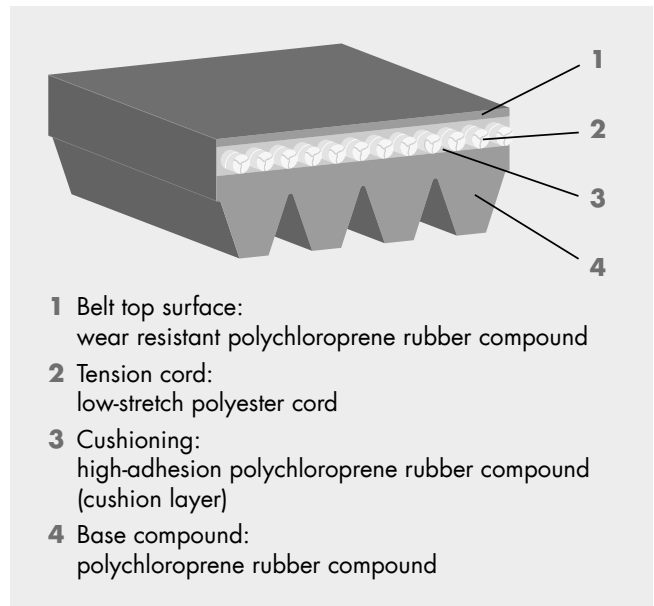

STANDARD RANGE

RIBBED BELTS

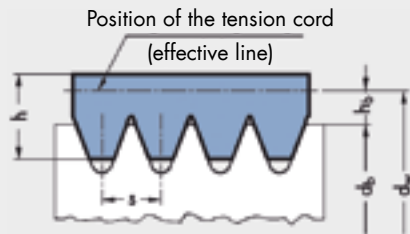

$$d_w = d_b + 2 h_b$$

Profile		PH	PJ	PK	PL	PM
Rib pitch	s [mm]	1.60	2.34	3.56	4.70	9.40
Belt thickness	≈ h [mm]	2.50	3.30	4.60	7.00	13.00
Belt speed	≈ v [m/s]	60	60	50	40	30
Minimum pulley diameter	d _{b min} [mm]	13	20	45	75	180
Effective line difference	h _b	0.80	1.25	1.60	3.50	5.00

Profile PH				Profile PJ					
Effective length L _b		Effective length L _b		Effective length L _b		Effective length L _b		Effective length L _b	
[mm]	[inch]	[mm]	[inch]	[mm]	[inch]	[mm]	[inch]	[mm]	[inch]
698	27.50	1397	55.00	280	11.00	1130	44.50	1915	75.40
735	28.90	1439	56.70	330	13.00	1150	45.30	1930	76.00
762	30.00	1475	58.10	356	14.00	1168	46.00	1956	77.00
813	32.00	1600	63.00	362	14.30	1194	47.00	1965	77.40
858	33.80	1854	73.00	381	15.00	1200	47.30	1981	78.00
864	34.00	1895	74.60	406	16.00	1222	48.10	1992	78.40
886	34.90	1915	75.40	414	16.30	1244	49.00	2083	82.00
955	37.60	1930	76.00	432	17.00	1262	49.70	2155	84.80
965	38.00	1956	77.00	457	18.00	1270	50.00	2210	87.00
975	38.40	1992	78.40	483	19.00	1285	50.60	2337	92.00
990	39.00	2083	82.00	508	20.00	1301	51.20	2489	98.00
1016	40.00	2155	84.80	559	22.00	1309	51.50		
1080	42.50			584	23.00	1316	51.80		
1092	43.00			610	24.00	1321	52.00		
1096	43.10			660	26.00	1333	52.50		
1168	46.00			711	28.00	1355	53.40		
1194	47.00			723	28.50	1371	54.00		
1200	47.20			737	29.00	1397	55.00		
1222	48.10			762	30.00	1428	56.20		
1230	48.40			813	32.00	1439	56.70		
1262	49.70			836	32.90	1475	58.10		
1270	50.00			864	34.00	1549	61.00		
1285	50.60			914	36.00	1600	63.00		
1290	50.80			955	37.60	1651	65.00		
1301	51.20			965	38.00	1663	65.50		
1309	51.50			1016	40.00	1752	69.00		
1316	51.80			1092	43.00	1780	70.00		
1321	52.00			1105	43.50	1854	73.00		
1333	52.50			1110	43.70	1895	74.60		
1371	54.00			1123	44.20	1910	75.20		

Note: Individually designed ribbed belts may deviate from the standard composition. Please contact our Applications Engineering Department!

Non standard lengths on request.
Maximum number of ribs: Please contact our Applications Engineering Department.
Profile PH is a non stock item.

Ordering example:

For a five-rib ribbed belt with profile PJ
with an effective length 660 L_b: optibelt RB 5 PJ 660 L_b

STANDARD RANGE

RIBBED BELTS



Profile PK						Profile PL		Profile PM	
Effective length L _b		Effective length L _b		Effective length L _b		Effective length L _b		Effective length L _b	
[mm]	[inch]	[mm]	[inch]	[mm]	[inch]	[mm]	[inch]	[mm]	[inch]
630•	24.80	1290•	50.80	2515•	99.00	954	37.50	2286	90.00
648	25.50	1321•	52.00	2845•	112.00	991	39.00	2388	94.00
698	27.50	1330	52.40			1075	42.30	2515	99.00
730	28.70	1345	53.00			1194	47.00	2693	106.00
775	30.50	1371•	54.00			1270	50.00	2832	111.50
800	31.50	1397•	55.00			1333	52.50	2921	115.00
812	32.00	1439•	56.70			1371	54.00	3010	118.50
830	32.70	1460	57.50			1397	55.00	3124	123.00
865	34.00	1520	59.80			1422	56.00	3327	131.00
875	34.50	1560	61.40			1562	61.50	3531	139.00
890	35.00	1570	61.80			1613	63.50	3734	147.00
913	36.00	1600•	63.00			1664	65.50	4089	161.00
920	36.20	1655	65.20			1715	67.50	4191	165.00
940	37.00	1690	66.50			1764	69.50	4470	176.00
954	37.60	1755	69.10			1803	71.00	4648	183.00
962	37.80	1854•	73.00			1841	72.50	5029	198.00
990	39.00	1885	74.20			1943	76.50	5410	213.00
1015	40.00	1930•	76.00			1981	78.00	6121	241.00
1080	42.50	1956•	77.00			2020	79.50	6883•	271.00
1090	43.00	1980	78.00			2070	81.50	7646•	301.00
1125	44.30	2030	79.90			2096	82.50	8408•	331.00
1150	45.30	2050	80.70			2134	84.00	9169•	361.00
1165	45.90	2080	82.00			2197	86.50	9931•	391.00
1190	46.80	2120	83.50			2235	88.00	10693•	421.00
1200•	47.20	2145	84.40			2324	91.50	12217•	481.00
1222•	48.10	2170	85.40			2362	93.00	13741•	541.00
1230•	48.40	2235•	88.00			2476	97.50	15266•	601.00
1245	49.00	2255	88.80			2515	99.00		
1270•	50.00	2362•	93.00			2705	106.50		
1285•	50.60	2460	96.90			2743	108.00		
						2845	112.00		
						2895	114.00		
						2921	115.00		
						2997	118.00		
						3086	121.50		
						3124	123.00		
						3289	129.50		
						3327	131.00		
						3492	137.50		
						3696	145.50		
						4051	159.50		
						4191	165.00		
						4470	176.00		
						4622	182.00		
						5029	198.00		
						5385	212.00		
						6096	240.00		

Note: Individually designed ribbed belts may deviate from the standard composition. Please contact our Applications Engineering Department!

Non standard lengths on request.
 Maximum number of ribs: Please contact our Applications Engineering Department.
 • non stock items

DRIVE DESIGN

ABBREVIATIONS USED IN FORMULAE



a	= Drive centre distance	[mm]	n_g	= Speed of large pulley	[rpm]
a_{nom}	= Drive centre distance, calculated with a standard belt length	[mm]	n_k	= Speed of small pulley	[rpm]
c_1	= Arc of contact correction factor		n_1	= Speed of driver pulley	[rpm]
c_2	= Drive service factor		n_2	= Speed of driven pulley	[rpm]
c_3	= Belt length correction factor		P	= Motor or normal running power	[kW]
d_{bg}	= Effective diameter of large pulley	[mm]	P_B	= Design power	[kW]
d_{bk}	= Effective diameter of small pulley	[mm]	P_N	= Power rating per rib	[kW]
d_{b1}	= Effective diameter of driver pulley	[mm]	s	= Drive span length	[mm]
d_{b2}	= Effective diameter of driven pulley	[mm]	S_a	= Minimum static shaft loading	[N]
E	= Belt deflection per 100 mm span length	[mm]	T	= Minimum static belt tension per rib	[N]
E_a	= Belt deflection for a given span length	[mm]	v	= Belt speed	[m/s]
f	= Load used to set belt tension per rib	[N]	x	= Minimum adjustment required above drive centre distance a_{nom} to compensate for tensioning and retensioning	[mm]
h	= Belt thickness	[mm]	y	= Minimum adjustment required below drive centre distance a_{nom} to allow for belt installation	[mm]
h_b	= Effective line difference	[mm]	z	= Number of ribs	
i	= Speed ratio		α	= Angle of belt run = $90^\circ - \frac{\beta}{2}$	°[degrees]
k	= Constant for calculation of centrifugal force		β	= Arc of contact on small pulley	°[degrees]
L	= Span length	[mm]			
L_{bSt}	= Standard belt effective length	[mm]			
L_{bth}	= Calculated belt effective length	[mm]			

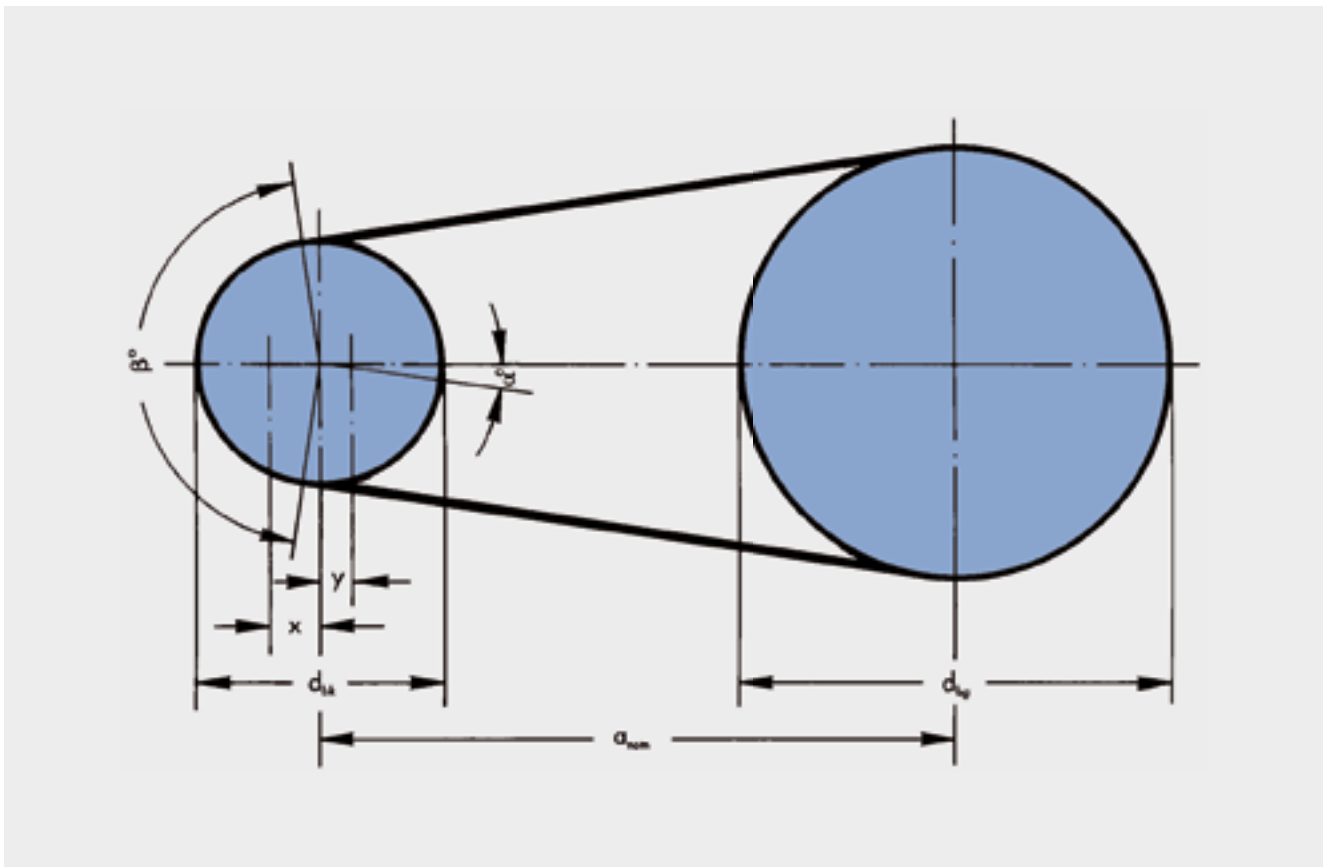

DRIVE DESIGN

OPTIBELT POWER RATING P_N – ARC OF CONTACT CORRECTION FACTOR c_1



Optibelt power ratings P_N shown in tables 5 to 9 are based on internationally recognised formulae. These formulae contain material constants which must be used in accordance with the practices of the individual manufacturers. The P_N power rating formula is based on a specific tension ratio between the tight and slack sides of the belt. The P_N power rating tables refer to the smallest loaded pulley in the drive. The belt power ratings P_N from the tables are given for:

- the effective diameter of small pulley d_{bk}
- the speed of small pulley n_k
- speed ratio i
- the arc of contact of the belt on small pulley $\beta = 180^\circ$
- the ideal belt length for the particular belt profile

From the given drive data, the power rating per rib can be found which must then be modified by application of the arc of contact correction factor c_1 and belt length correction factor c_3 .

Intermediate values can be found by linear interpolation.

The arc of contact correction factor c_1 corrects the power rating P_N when the arc of contact of the belt is smaller than 180° , since the P_N value of the arc of contact $\beta = 180^\circ$ was determined on the small pulley d_{bk} .

Table 1

$\frac{d_{bg} - d_{bk}}{a_{nom}}$	$\beta \approx$	c_1
0	180°	1.00
0.05	177°	1.00
0.10	174°	1.00
0.15	171°	0.99
0.20	168°	0.99
0.25	165°	0.99
0.30	162°	0.99
0.35	160°	0.99
0.40	156°	0.98
0.45	153°	0.98
0.50	150°	0.98
0.55	147°	0.97
0.60	144°	0.97
0.65	141°	0.97
0.70	139°	0.96
0.75	136°	0.96
0.80	133°	0.95
0.85	130°	0.95
0.90	126°	0.94
0.95	123°	0.94
1.00	119°	0.93
1.05	115°	0.92
1.10	112°	0.92
1.15	109°	0.91
1.20	106°	0.90
1.25	103°	0.89
1.30	100°	0.89
1.35	96°	0.87
1.40	92°	0.86
1.45	88°	0.85
1.50	84°	0.83
1.55	80°	0.82
1.60	77°	0.80

Intermediate lengths can be calculated by linear interpolation!

DRIVE DESIGN

BELT LENGTH CORRECTION FACTOR c_3



The belt length correction factor c_3 takes into account the flex rate in the particular belt profile in relationship to a standard effective length.

This results in the following relationships:

ribbed belt length used > standard effective length $c_3 > 1.0$

ribbed belt length used = standard effective length $c_3 = 1.0$

ribbed belt length used < standard effective length $c_3 < 1.0$

$$c_3 = 1 + \left[\left(\frac{L_b}{L_{bo}} \right)^{0.09} - 1 \right] \cdot 2.4$$

L_b = ribbed belt length used
 L_{bo} = standard effective length

Table 2

Profile PH				Profile PJ			
Effective length L_b [mm]	c_3	Effective length L_b [mm]	c_3	Effective length L_b [mm]	c_3	Effective length L_b [mm]	c_3
559	0.96	1956	1.19	280	0.74	1309	1.05
698	0.96	1992	1.20	330	0.76	1316	1.05
735	0.97	2083	1.21	356	0.78	1321	1.05
762	0.98	2155	1.22	362	0.78	1333	1.05
813	1.00			381	0.79	1355	1.06
858	1.01			406	0.80	1371	1.06
864	1.01			414	0.81	1397	1.06
886	1.01			432	0.82	1428	1.07
914	1.02			457	0.83	1439	1.07
955	1.03			483	0.84	1475	1.08
965	1.03			508	0.85	1549	1.09
975	1.03			559	0.87	1600	1.10
990	1.03			584	0.88	1651	1.10
1016	1.04			610	0.89	1663	1.10
1080	1.06			660	0.90	1752	1.12
1092	1.06			711	0.92	1780	1.12
1096	1.06			723	0.92	1854	1.13
1168	1.07			762	0.93	1895	1.13
1194	1.08			813	0.95	1910	1.14
1200	1.08			836	0.95	1915	1.14
1222	1.08			864	0.96	1930	1.14
1230	1.09			914	0.97	1956	1.14
1262	1.09			955	0.98	1965	1.14
1270	1.09			965	0.98	1981	1.14
1285	1.10			1016	1.00	1992	1.14
1290	1.10			1092	1.01	2083	1.16
1301	1.10			1105	1.01	2155	1.17
1309	1.10			1110	1.01	2210	1.17
1316	1.10			1123	1.02	2337	1.18
1321	1.10			1130	1.02	2489	1.20
1333	1.10			1150	1.02		
1371	1.11			1168	1.03		
1397	1.11			1194	1.03		
1439	1.12			1200	1.03		
1475	1.13			1222	1.04		
1600	1.15			1244	1.04		
1854	1.18			1262	1.04		
1895	1.18			1270	1.04		
1915	1.19			1285	1.05		
1930	1.19			1301	1.05		

Additional sizes on request.

DRIVE DESIGN

BELT LENGTH CORRECTION FACTOR c_3



Table 2

Profile PK				Profile PL				Profile PM	
Effective length L_b [mm]	c_3	Effective length L_b [mm]	c_3	Effective length L_b [mm]	c_3	Effective length L_b [mm]	c_3	Effective length L_b [mm]	c_3
559	0.78	1956	1.04	954	0.83	4051	1.14	2286	0.87
630	0.81	1980	1.05	991	0.84	4191	1.15	2388	0.88
648	0.81	2030	1.05	1075	0.86	4470	1.16	2515	0.89
698	0.82	2050	1.05	1194	0.88	4622	1.17	2693	0.91
730	0.84	2080	1.06	1270	0.89	5029	1.19	2832	0.92
775	0.85	2120	1.06	1333	0.90	5385	1.21	2921	0.92
800	0.85	2145	1.06	1371	0.91	6096	1.24	3010	0.93
812	0.86	2170	1.07	1397	0.91			3124	0.94
830	0.86	2235	1.09	1422	0.91			3327	0.95
865	0.87	2362	1.09	1562	0.93			3531	0.96
875	0.87	2460	1.09	1613	0.94			3734	0.98
890	0.88	2515	1.10	1664	0.95			4089	1.00
913	0.88	2743	1.12	1715	0.95			4191	1.00
920	0.88	2845	1.13	1764	0.96			4470	1.01
940	0.89			1803	0.96			4648	1.02
954	0.89			1841	0.97			5029	1.04
962	0.89			1943	0.98			5410	1.06
990	0.90			1981	0.98			6121	1.08
1015	0.90			2020	0.99			6883	1.11
1080	0.92			2070	0.99			7646	1.13
1090	0.91			2096	1.00			8408	1.16
1100	0.92			2134	1.00			9169	1.18
1125	0.93			2197	1.01			9931	1.19
1150	0.93			2235	1.01			10693	1.21
1165	0.93			2324	1.02			12217	1.24
1190	0.94			2362	1.02			13741	1.27
1200	0.94			2476	1.03			15266	1.30
1222	0.94			2515	1.03				
1230	0.94			2705	1.05				
1245	0.95			2743	1.05				
1270	0.95			2845	1.06				
1285	0.95			2895	1.07				
1290	0.95			2921	1.07				
1321	0.96			2997	1.07				
1330	0.96			3086	1.08				
1345	0.96			3124	1.08				
1371	0.97			3289	1.09				
1397	0.97			3327	1.10				
1439	0.98			3492	1.11				
1460	0.98			3696	1.12				
1520	0.99								
1560	0.99								
1570	1.00								
1600	1.00								
1655	1.01								
1690	1.01								
1755	1.02								
1854	1.03								
1885	1.04								
1930	1.04								

Additional sizes on request.

DRIVE DESIGN

MINIMUM ALLOWANCE x/y ABOVE AND BELOW DRIVE CENTRE DISTANCE a_{nom}



Table 3

Effective length L_b [mm]	Minimum allowance x [mm] - for tensioning and retensioning	Minimum allowance y [mm] - for ease of fitting				
		Profile PH	Profile PJ	Profile PK	Profile PL	Profile PM
≤ 500	10	10	10	—	—	—
$> 500 \leq 1000$	15	15	15	20	25	—
$> 1000 \leq 1500$	20	15	15	20	25	—
$> 1500 \leq 2000$	25	15	15	20	25	—
$> 2000 \leq 2500$	30	20	20	20	25	40
$> 2500 \leq 3000$	35	20	20	25	30	40
$> 3000 \leq 4000$	45	—	—	25	30	45
$> 4000 \leq 5000$	55	—	—	30	35	45
$> 5000 \leq 6000$	65	—	—	30	35	50
$> 6000 \leq 7500$	85	—	—	—	—	55

Minimum Allowance

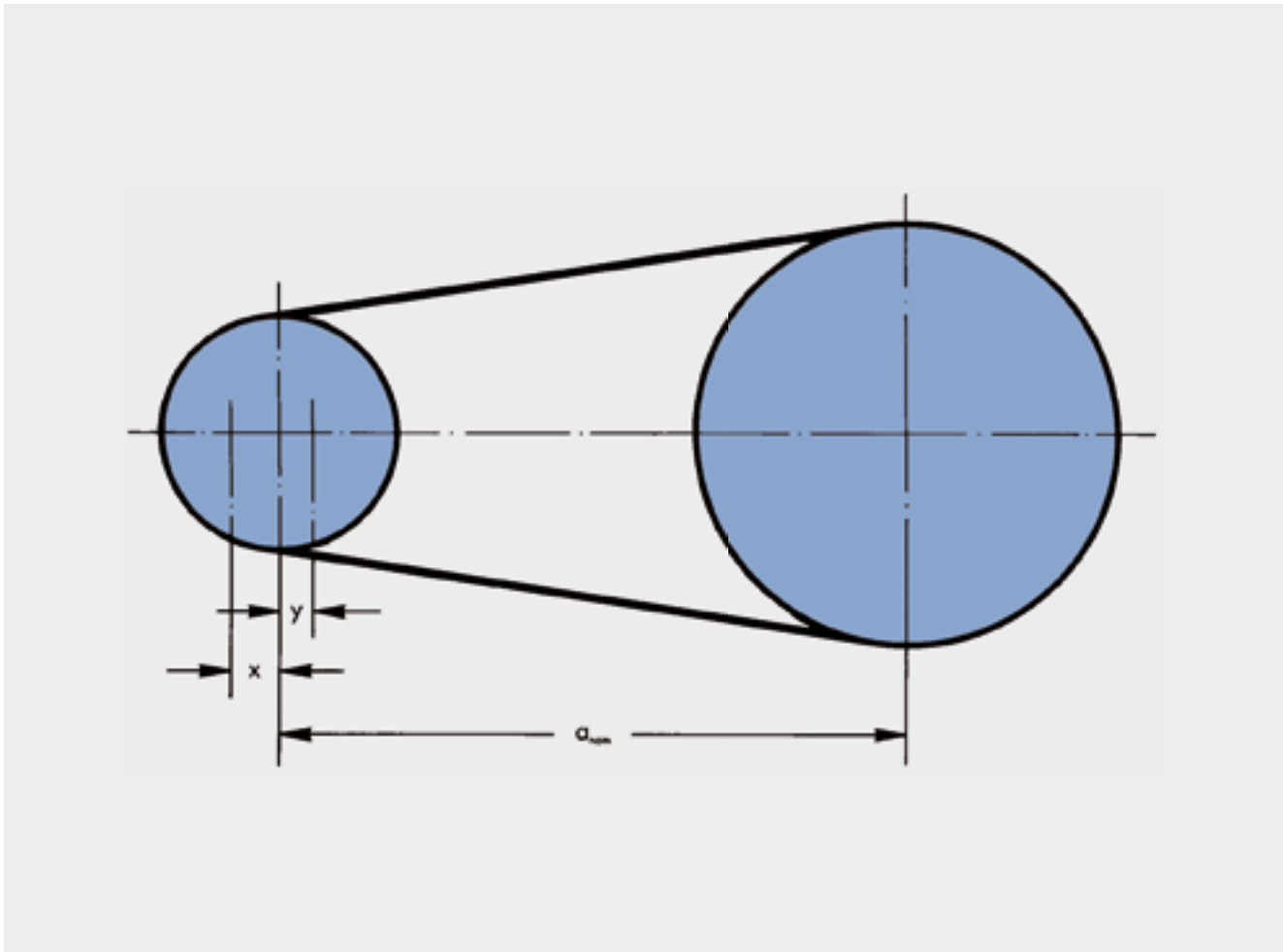



The drive service factor c_2 takes into account the length of time the drive is operational in a 24 hour period and the type of driver and driven units. It applies exclusively to two pulley drives. It does not take into account other working conditions, such as drives with tension, guide and idler pulleys. Pages 33 to 34 give the design bases for drives with more than two pulleys. Extreme operating conditions such as aggressive dust, particularly high temperatures or the influence of various media are **not** considered. Since it is practically impossible to condense every possible combination of drive unit/driven machine/operating conditions into a standard-compliant form the drive service factors are **guide values**. In special cases

e.g. high starting load (direct starting of fans), drives with high starting frequency, unusual shock loading, or the regular acceleration/deceleration of mass, the load factor should be increased.

Typical value:

Where the starting load is more than 1.8 times the standard running load, the value should be divided by 1.5 to obtain the minimum drive service factor c_2 ; example: starting load factor $M_A = 3.0$; c_2 selected as 2.0. Where the application is especially problematical please consult our applications engineers.

Table 4

Types of Driven Machine		Types of Prime Mover					
		Hours per day duty					
		10 and under	over 10 to 16	over 16	10 and under	over 10 to 16	over 16
Consistent duty, only low masses to be accelerated	Agitators for liquids with uniform consistency, generators up to 0.05 kW, small conveyor belts for lightweight material, fans up to 0.05 kW, rotary pumps up to 0.05 kW	AC and three-phase motors with normal starting load (up to 1.8 times normal running load), e.g. synchronous and single-phase motors with auxiliary phase, three-phase motors with direct on-line start, star delta or commutator starter, DC shunt wound motors, internal combustion engines and turbines n > 600 rpm			AC and three-phase motors with high starting load (more than 1.8 times normal running load), e.g. single-phase motors with high starting torque, DC motors series and compound wound, internal combustion engines and turbines n ≤ 600 rpm		
		1.1	1.1	1.2	1.1	1.2	1.3
Consistent light duty operation, low masses to be accelerated	Conveyor belts for lightweight material, fans from 0.06 to 0.1 kW, rotary pumps from 0.06 to 0.1 kW	1.1	1.2	1.3	1.2	1.3	1.4
Inconsistent duty operation, medium-sized masses to be accelerated	Vibrating screens, pit fans, agitators for liquids with fluctuating consistency, compressors, screw presses, woodworking machinery, conveyor belts for heavy material, elevators, conveyor belts, fans above 0.8 kW, drills, milling machines, grinding machines, light lathes, bakery machinery, circular spinning frames, rotary pumps above 0.11 kW, laundry machinery	1.2	1.3	1.4	1.3	1.4	1.5
Inconsistent medium duty, medium-sized shocks and masses to be accelerated	Kneaders, mills, mixers, pumps, drying drums, general milling equipment, centrifuges, agitators for plastic materials with fluctuating consistency, bucket conveyors, centrifugal fans, parallel planing machines, weaving looms	1.3	1.4	1.5	1.4	1.5	1.6
Inconsistent duty operation, high shocks and masses to be accelerated	Paper making machinery, plate conveyors, slag mills, calenders, drilling rigs, heavy duty lathes, punches, shears, draw benches, piston pumps up to 2 cylinders	1.4	1.5	1.6	1.5	1.7	1.8
Inconsistent duty operation, extra high masses to be accelerated, extra high shocks	Dredgers, heavy duty grinders, rolling mills, mixers, sawmills, calenders	1.6	1.7	1.8	1.6	1.8	2.0

DRIVE DESIGN

A GUIDE TO SELECTING RIBBED BELT PROFILES



By using the following diagram and considering economy and size it is possible to determine the best ribbed belt profile. Optimum utilisation of power and efficiency is achieved by the selection of the largest possible pulley diameter in relation to the profile used. The limits to the permissible circumferential speeds for ribbed belts must be observed:

- Profile PH $v_{max} = 60$ m/s
- Profile PJ $v_{max} = 60$ m/s
- Profile PK $v_{max} = 50$ m/s
- Profile PL $v_{max} = 40$ m/s
- Profile PM $v_{max} = 35$ m/s

Experience has shown that minimum pulley diameters should be avoided. These drives require a larger number of ribs and consequently broad pulleys. As a result, they are cost-intensive. The ribbed belt width should not be larger than the effective diameter of the small pulley.

In such borderline cases the use of the next smaller belt profile on similar pulley diameters will often save both cost and space.

A check is also advisable if the point of interprofile in the selection diagram used lies in the boundary areas between two profiles.

Please contact our Applications Engineering Department in the case of higher circumferential speeds.

Diagram 1

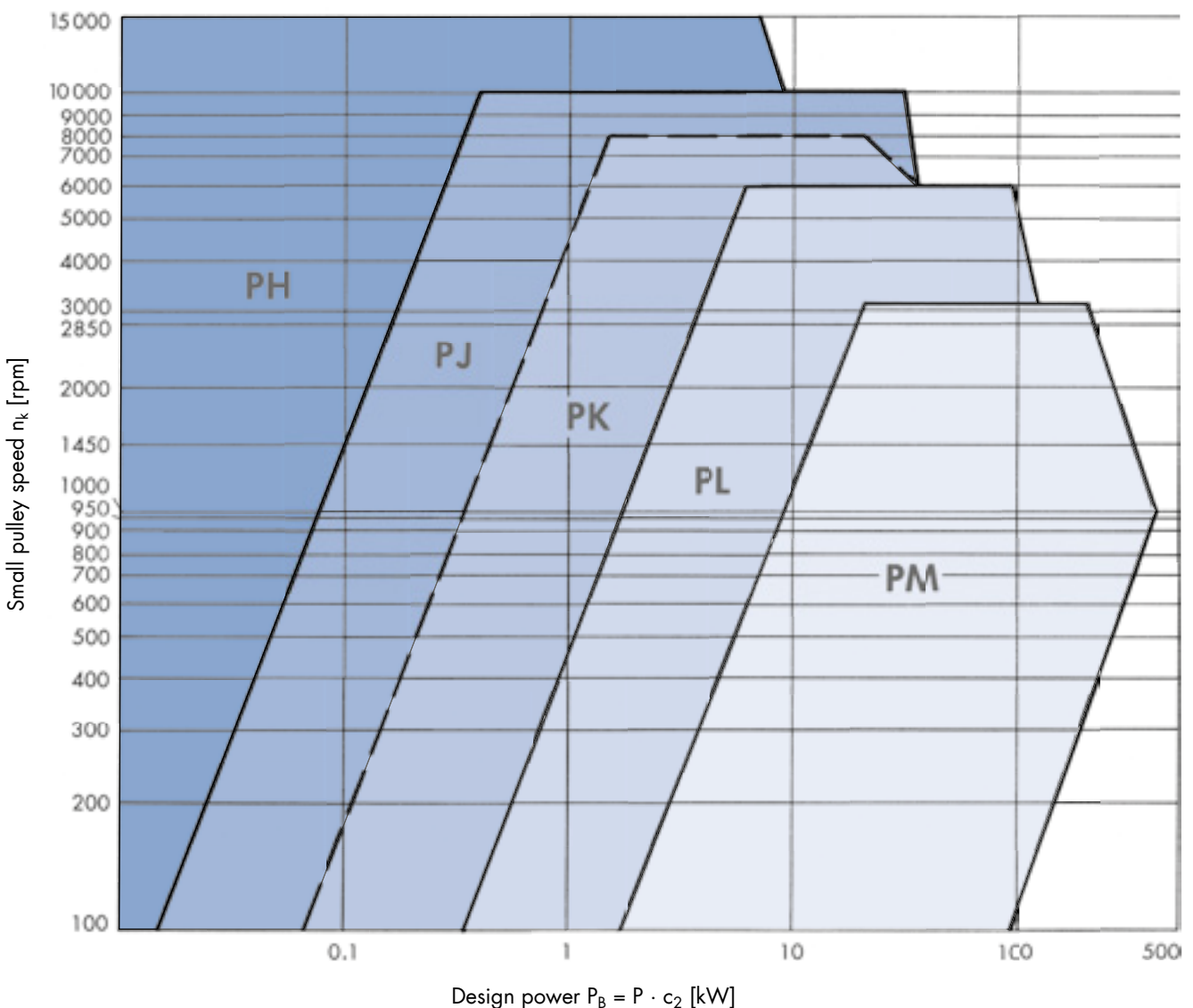

DRIVE DESIGN

FORMULAE AND CALCULATION EXAMPLE



Prime Mover



Electric motor
 $P = 13 \text{ kW}$
 $n_1 = 2440 \text{ rpm}$
 Start up: direct
 Starting torque: $M_A = 2.7 M_N$

Drive Conditions

Operational hours per day: 8 hours
 Number of starts: 20 per day
 Normal ambient temperature,
 no exposure to oil and water

Drive centre distance: between
 350 and 400 mm acceptable
 Effective diameter of driver pulley:
 $d_{b1} \leq 140 \text{ mm}$

Driven Machine

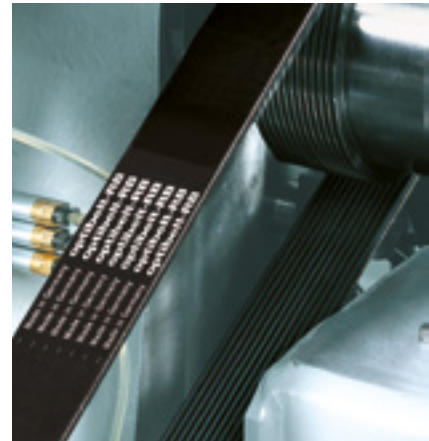

Grinding spindle
 $P = 13 \text{ kW}$
 $n_2 = 3100 \pm 100 \text{ rpm}$
 Start up: from idling

Formulae

Drive service factor

c_2 from table 4, page 20

Design power

$$P_B = P \cdot c_2$$

Belt profile selection

from diagram 1, page 21

Speed ratio

$$i = \frac{n_1}{n_2} = \frac{d_{w2}}{d_{w1}} = \frac{d_{b2} + 2 h_b}{d_{b1} + 2 h_b}$$

h_b see page 32

Effective diameters of ribbed belt pulleys

d_{b1} see page 45

$$d_{b2} = d_{b1} \cdot i + 2 h_b (i - 1)$$

when d_{b2} is known:

$$d_{b1} = \frac{d_{b2}}{i} + 2 h_b \left(\frac{1}{i} - 1 \right)$$

Calculation Example

$$c_2 = 1.6$$

$$P_B = 13 \cdot 1.6 = 20.80 \text{ kW}$$

Profile PL

$$i = \frac{2440}{3173} = 0.769$$

$d_{b1} = 123 \text{ mm}$ selected

$$d_{b2} = 123 \text{ mm} \cdot 0.769 + 2 \cdot 3.5 (0.769 - 1) = 92.97 \text{ mm}$$

$d_{b2} = 93 \text{ mm}$ – see page 44



Formulae

Recalculation of speed of driven machine

$$i_{\text{actual}} = \frac{d_{w2}}{d_{w1}} = \frac{d_{b2} + 2 h_b}{d_{b1} + 2 h_b}$$

$$n_{2 \text{ actual}} = \frac{n_1}{i_{\text{actual}}}$$

Drive centre distance (suggested)

Recommendation: $a > 0.7 (d_{bg} + d_{bk})$

$a < 2 (d_{bg} + d_{bk})$

Effective length of ribbed belt

$$L_{bth} \approx 2 a + 1.57 (d_{bg} + d_{bk}) + \frac{(d_{bg} - d_{bk})^2}{4 a}$$

Actual:

$$L_{bth} = 2 a \cdot \sin \frac{\beta}{2} + \frac{\pi}{2} (d_{bg} + d_{bk}) + \frac{\alpha \cdot \pi}{180^\circ} (d_{bg} - d_{bk})$$

Drive centre distance

Calculated from L_{bSt} and L_{bth}

$$\text{(when } L_{bSt} > L_{bth}) \quad a_{\text{nom}} \approx a + \frac{L_{bSt} - L_{bth}}{2}$$

$$\text{(when } L_{bSt} < L_{bth}) \quad a_{\text{nom}} \approx a - \frac{L_{bth} - L_{bSt}}{2}$$

Actual:

$$a_{\text{nom}} = \frac{L_{bSt} - \frac{\pi}{2} (d_{bg} + d_{bk})}{4} +$$

$$\sqrt{\left[\frac{L_{bSt} - \frac{\pi}{2} (d_{bg} + d_{bk})}{4} \right]^2 - \frac{(d_{bg} - d_{bk})^2}{8}}$$

Minimum allowance x/y above and below drive centre distance a_{nom}

x/y from table 3, page 19

Calculation Example

$$i_{\text{actual}} = \frac{93 + 2 \cdot 3.5}{123 + 2 \cdot 3.5} = \mathbf{0.769}$$

$$n_{2 \text{ actual}} = \frac{2440}{0.769} = \mathbf{3173 \text{ rpm}}$$

Required:
3100 ± 100 rpm
(Calculated speed meets requirement)

$a = \mathbf{380 \text{ mm}}$ suggested

$$L_{bth} \approx 2 \cdot 380 + 1.57 \cdot (123 + 93) + \frac{(123 - 93)^2}{4 \cdot 380} \approx 1099.7 \text{ mm}$$

Nearest standard length from page 14 selected

$L_{bSt} = \mathbf{1075 \text{ mm}}$

$$a_{\text{nom}} \approx 380 - \frac{1099.7 - 1075}{2} \approx \mathbf{367.65 \text{ mm}}$$

$x \geq \mathbf{20 \text{ mm}} / y \geq \mathbf{25 \text{ mm}}$

Speed

$$v = \frac{d_{wk} \cdot n_k}{19100} = \frac{(d_{bk} + 2 \cdot h_b) \cdot n_k}{19100}$$

$$v = \frac{(93 + 2 \cdot 3.5) \cdot 3173}{19100} = \mathbf{16.61 \text{ m/s}}$$



Formulae

Arc of contact correction factor and arc of contact

$$\frac{d_{bg} - d_{bk}}{a_{nom}}$$

Approximate β° and c_1 from table 1, page 16

$$\text{Actual: } \cos \frac{\beta}{2} = \frac{d_{bg} - d_{bk}}{2 a_{nom}}$$

Belt length correction factor

c_3 from table 2, page 17

Power rating per rib

$$P_N \text{ for } \begin{cases} d_{bk} = 93 \text{ mm} \\ n_k = 3173 \text{ rpm} \\ i^* = \frac{1}{0.769} = 1.3 \end{cases} \quad \begin{array}{l} \text{Profile PL} \\ \text{from table 8, page 29} \end{array}$$

The condition $i \geq 1$ applies for selecting the speed ratio power increment.

Number of ribs

$$z = \frac{P \cdot c_2}{P_N \cdot c_1 \cdot c_3}$$

Minimum static belt tension per rib

$$T \approx \frac{500 \cdot (2.03 - c_1) \cdot P_B}{c_1 \cdot z \cdot v} + k \cdot v^2$$

k from table

Profile	k	f [N] (per rib)
PH	0.005	3.0
PJ	0.009	5.0
PK	0.020	7.5
PL	0.036	10.0
PM	0.123	25.0

Minimum static shaft loading

$$S_\alpha \approx 2 T \cdot \sin \frac{\beta}{2} \cdot z$$

Belt deflection for a given span length

$$E_\alpha \approx \frac{E \cdot L}{100}$$

E from diagram 2, page 49

$$L = a_{nom} \cdot \sin \frac{\beta}{2}$$

For explanation see chapter on tensioning on page 48

Calculation Example

$$\frac{123 - 93}{368} = 0.082$$

$$\left. \begin{array}{l} \beta \approx 175^\circ \\ c_1 = 1.0 \end{array} \right\} \text{linearly interpolated}$$

$$c_3 = 0.86$$

$$P_N = 2.28 + 0.2 = 2.48 \text{ kW}$$

$$z = \frac{13 \cdot 1.6}{2.48 \cdot 1.0 \cdot 0.86} = 9.74$$

Design:

1 optibelt RB ribbed belt 10 PL 1075

$$T \approx \frac{500 \cdot (2.03 - 1.0) \cdot 20.8}{1.0 \cdot 10 \cdot 16.6} + 0.036 \cdot 16.6^2 \approx 75 \text{ N}$$

$$S_\alpha \approx 2 \cdot 75 \cdot 0.9986 \cdot 10 \approx 1500 \text{ N}$$

$$E_\alpha \approx \frac{2.5 \cdot 367.0}{100} \approx 9 \text{ mm}$$

$$E \approx 2.5 \text{ mm}$$

$$L = 367.6 \cdot 0.9986 = 367.0 \text{ mm}$$

To design drive with:

- optibelt RB Ribbed Belt 10 PL 1075 L_b
- optibelt RBS Ribbed Belt Pulley for Taper Bushes TB 10 PL 123
- optibelt TB Taper Bush 2012 (bore diameter 14-50 mm)
- optibelt RBS Ribbed Belt Pulley for Taper Bushes TB 10 PL 93
- optibelt TB Taper Bushes 1610 (bore diameter 14-42 mm)



Tolerances/Indications

Prime mover	:	Electric motor	
Driven machine			
Design power	PB:	20.80 kW	
Driver unit output	P:	13.00 kW	
Driver pulley torque	M:	51 Nm	
Speed of driver unit	n₁:	2440 1/min	
Effective output speed	n₂:	3172 1/min	-55 1/min
	d_{b1}:	123.00 mm	
	d_{b2}:	93.00 mm	
	:	1075 mm	
Effective drive centre distance	a:	367.55 mm	-12.452 mm
Effective speed ratio	i:	0.77	1.7 %
Allowance for installation	y:	25.00 mm	
Allowance for tensioning	x:	20.00 mm	
Effective drive service factor	c₂:	1.64	
Belt speed	v:	16.61 m/s	
Flexing cycles	f _B :	30.90 1/s	
Power rating per belt	P _N :	2.49 kW	
Arc of contact correction factor	c ₁ :	1.00	
Belt length correction factor	c ₃ :	0.86	
Arc of contact for small pulley	β:	175.32 °	
Pulley face width	b ₂ :	48.90 mm	
Span length	l:	367.24 mm	
Calculated number of belts	zth:	9.74	for predetermined c ₂ = 1.60
Drive unit weight	:	- kg	
Static shaft loading, initial installation	Sast:	1941 -	
Static shaft loading, used belt	Sast:	1493 N	
Dynamic shaft loading	Sadyn:	1308 N	

Belt tension methods	Initial installation	Operating voltage	
		New belt	Used belt
for predetermined c ₂ =	1.60		
1. optibelt OPTIKRIK II	Static shaft loading per belt:	971 N	747 N
2. Deflection with tension gauge	Test load:	100 N	100 N
	Deflection:	7.34 mm	8.45 mm
3. Length addition per 1000 mm belt length	:	2.85 mm	2.11 mm
4. optibelt TT 3 / optibelt TT MINI Frequency Tension Gauge	Frequency:	70.72 1/s	62.02 1/s

Concerning liability consult our general terms and conditions.

PROFILE PH

POWER RATING P_N [kW] PER RIB FOR $\beta = 180^\circ$

AND $L_b = 813$ mm



Table 5

v [m/s]	n_k [rpm]	Effective diameter of small pulley d_{sk} [mm]											Arc of contact correction factor [kW] per rib for speed ratio i			
		13	17	20	25	31,5	35,5	40	45	50	63	71	80	1.01 to 1.05	1.06 to 1.26	1.27 > 1.57 to 1.57
	700	0.01	0.02	0.02	0.03	0.04	0.05	0.05	0.06	0.07	0.09	0.10	0.11			
	950	0.01	0.02	0.03	0.04	0.05	0.06	0.07	0.08	0.09	0.11	0.13	0.15			
	1450	0.02	0.03	0.04	0.06	0.08	0.09	0.10	0.11	0.13	0.17	0.19	0.21			
	2850	0.03	0.05	0.07	0.10	0.14	0.16	0.18	0.21	0.23	0.30	0.34	0.38	0.01	0.01	
	100	0.00	0.00	0.00	0.01	0.01	0.01	0.01	0.01	0.01	0.02	0.02	0.02			
	300	0.01	0.01	0.01	0.01	0.02	0.02	0.02	0.03	0.03	0.04	0.05	0.05			
	500	0.01	0.01	0.02	0.02	0.03	0.03	0.04	0.04	0.05	0.06	0.07	0.08			
	700	0.01	0.02	0.02	0.03	0.04	0.05	0.05	0.06	0.07	0.09	0.10	0.11			
	900	0.01	0.02	0.03	0.04	0.05	0.06	0.07	0.08	0.08	0.11	0.12	0.14			
	1000	0.01	0.02	0.03	0.04	0.05	0.06	0.07	0.08	0.09	0.12	0.13	0.15			
	1100	0.02	0.02	0.03	0.04	0.06	0.07	0.08	0.09	0.10	0.13	0.15	0.17			
	1200	0.02	0.03	0.03	0.05	0.06	0.07	0.08	0.10	0.11	0.14	0.16	0.18			
	1300	0.02	0.03	0.04	0.05	0.07	0.08	0.09	0.10	0.12	0.15	0.17	0.19			
	1400	0.02	0.03	0.04	0.05	0.07	0.08	0.10	0.11	0.13	0.16	0.18	0.21			
	1500	0.02	0.03	0.04	0.06	0.08	0.09	0.10	0.12	0.13	0.17	0.19	0.22			
	1600	0.02	0.03	0.04	0.06	0.08	0.10	0.11	0.13	0.14	0.18	0.20	0.23			
	1700	0.02	0.04	0.05	0.06	0.09	0.10	0.12	0.13	0.15	0.19	0.22	0.24			
	1800	0.02	0.04	0.05	0.07	0.09	0.11	0.12	0.14	0.16	0.20	0.23	0.26			
	1900	0.02	0.04	0.05	0.07	0.10	0.11	0.13	0.15	0.16	0.21	0.24	0.27			
	2000	0.02	0.04	0.05	0.07	0.10	0.12	0.13	0.15	0.17	0.22	0.25	0.28			
	2100	0.02	0.04	0.06	0.08	0.10	0.12	0.14	0.16	0.18	0.23	0.26	0.29			
	2200	0.03	0.04	0.06	0.08	0.11	0.13	0.15	0.17	0.19	0.24	0.27	0.31			0.01
	2300	0.03	0.05	0.06	0.08	0.11	0.13	0.15	0.17	0.19	0.25	0.28	0.32			0.01
	2400	0.03	0.05	0.06	0.09	0.12	0.14	0.16	0.18	0.20	0.26	0.29	0.33			0.01
	2500	0.03	0.05	0.06	0.09	0.12	0.14	0.16	0.19	0.21	0.27	0.30	0.34			0.01
	2600	0.03	0.05	0.07	0.09	0.13	0.15	0.17	0.19	0.22	0.28	0.31	0.35			0.01
	2700	0.03	0.05	0.07	0.10	0.13	0.15	0.17	0.20	0.22	0.29	0.32	0.37			0.01
②	2800	0.03	0.05	0.07	0.10	0.13	0.16	0.18	0.21	0.23	0.30	0.33	0.38	0.01	0.01	
	2900	0.03	0.06	0.07	0.10	0.14	0.16	0.18	0.21	0.24	0.30	0.34	0.39	0.01	0.01	
	3000	0.03	0.06	0.08	0.10	0.14	0.17	0.19	0.22	0.24	0.31	0.35	0.40	0.01	0.01	
	3100	0.03	0.06	0.08	0.11	0.15	0.17	0.20	0.22	0.25	0.32	0.37	0.41	0.01	0.01	
	3200	0.03	0.06	0.08	0.11	0.15	0.17	0.20	0.23	0.26	0.33	0.38	0.42	0.01	0.01	
	3300	0.03	0.06	0.08	0.11	0.15	0.18	0.21	0.24	0.27	0.34	0.39	0.43	0.01	0.01	
	3400	0.04	0.06	0.08	0.12	0.16	0.18	0.21	0.24	0.27	0.35	0.39	0.44	0.01	0.01	
	3500	0.04	0.06	0.09	0.12	0.16	0.19	0.22	0.25	0.28	0.36	0.40	0.46	0.01	0.01	
	3600	0.04	0.07	0.09	0.12	0.17	0.19	0.22	0.26	0.29	0.37	0.41	0.47	0.01	0.01	
	3700	0.04	0.07	0.09	0.13	0.17	0.20	0.23	0.26	0.29	0.38	0.42	0.48	0.01	0.01	
	3800	0.04	0.07	0.09	0.13	0.17	0.20	0.23	0.27	0.30	0.38	0.43	0.49	0.01	0.01	0.01
	3900	0.04	0.07	0.09	0.13	0.18	0.21	0.24	0.27	0.31	0.39	0.44	0.50	0.01	0.01	0.01
	4000	0.04	0.07	0.10	0.13	0.18	0.21	0.24	0.28	0.31	0.40	0.45	0.51	0.01	0.01	0.01
	4100	0.04	0.07	0.10	0.14	0.19	0.22	0.25	0.29	0.32	0.41	0.46	0.52	0.01	0.01	0.01
	4200	0.04	0.08	0.10	0.14	0.19	0.22	0.25	0.29	0.33	0.42	0.47	0.53	0.01	0.01	0.01
	4400	0.04	0.08	0.10	0.15	0.20	0.23	0.26	0.30	0.34	0.43	0.49	0.55	0.01	0.01	0.01
	4600	0.04	0.08	0.11	0.15	0.21	0.24	0.27	0.31	0.35	0.45	0.51	0.57	0.01	0.01	0.01
	4800	0.05	0.08	0.11	0.16	0.21	0.25	0.28	0.33	0.37	0.47	0.52	0.59	0.01	0.01	0.01
	5000	0.05	0.09	0.12	0.16	0.22	0.26	0.29	0.34	0.38	0.48	0.54	0.60	0.01	0.01	0.01
	5200	0.05	0.09	0.12	0.17	0.23	0.26	0.30	0.35	0.39	0.50	0.56	0.62	0.01	0.01	0.01
	5400	0.05	0.09	0.12	0.17	0.24	0.27	0.31	0.36	0.40	0.51	0.57	0.64	0.01	0.01	0.01
	5600	0.05	0.09	0.13	0.18	0.24	0.28	0.32	0.37	0.42	0.53	0.59	0.66	0.01	0.01	0.01
	5800	0.05	0.10	0.13	0.18	0.25	0.29	0.33	0.38	0.43	0.54	0.61	0.67	0.01	0.01	0.01
	6000	0.05	0.10	0.13	0.19	0.26	0.30	0.34	0.39	0.44	0.56	0.62	0.69	0.01	0.01	0.01
	6200	0.06	0.10	0.14	0.19	0.26	0.31	0.35	0.40	0.45	0.57	0.64	0.70	0.01	0.01	0.01
	6400	0.06	0.11	0.14	0.20	0.27	0.31	0.36	0.41	0.46	0.58	0.65	0.72	0.01	0.01	0.01
	6600	0.06	0.11	0.14	0.20	0.28	0.32	0.37	0.42	0.47	0.60	0.66	0.73	0.01	0.01	0.02
	6800	0.06	0.11	0.15	0.21	0.29	0.33	0.38	0.43	0.49	0.61	0.68	0.75	0.01	0.01	0.02
	7000	0.06	0.11	0.15	0.21	0.29	0.34	0.39	0.44	0.50	0.62	0.69	0.76	0.01	0.01	0.02
	7200	0.06	0.12	0.15	0.22	0.30	0.35	0.40	0.45	0.51	0.63	0.70	0.77	0.01	0.01	0.02
⑤	7400	0.06	0.12	0.16	0.22	0.31	0.35	0.41	0.46	0.52	0.65	0.71	0.78	0.01	0.01	0.02
	7600	0.06	0.12	0.16	0.23	0.31	0.36	0.42	0.47	0.53	0.66	0.73	0.79	0.01	0.01	0.02
	7800	0.06	0.12	0.17	0.23	0.32	0.37	0.42	0.48	0.54	0.67	0.74	0.80	0.01	0.01	0.02
	8000	0.07	0.13	0.17	0.24	0.33	0.38	0.43	0.49	0.55	0.68	0.75	0.81	0.01	0.01	0.02
	8200	0.07	0.13	0.17	0.24	0.33	0.38	0.44	0.50	0.56	0.69	0.76	0.82	0.01	0.01	0.02
	8400	0.07	0.13	0.18	0.25	0.34	0.39	0.45	0.51	0.57	0.70	0.77	0.83	0.01	0.02	0.02
	8600	0.07	0.13	0.18	0.25	0.34	0.40	0.46	0.52	0.58	0.71	0.78	0.83	0.01	0.02	0.02
	8800	0.07	0.13	0.18	0.26	0.35	0.41	0.46	0.53	0.59	0.72	0.78	0.84	0.01	0.02	0.02
	9000	0.07	0.14	0.18	0.26	0.36	0.41	0.47	0.54	0.59	0.73	0.79	0.85	0.01	0.02	0.02
	9200	0.07	0.14	0.19	0.27	0.36	0.42	0.48	0.54	0.60	0.74	0.80	0.85	0.01	0.02	0.02
	9400	0.07	0.14	0.19	0.27	0.37	0.43	0.49	0.55	0.61	0.74	0.81	0.86	0.01	0.02	0.02
	9600	0.07	0.14	0.19	0.28	0.38	0.43	0.50	0.56	0.62	0.75	0.81	0.86	0.01	0.02	0.02
	9800	0.08	0.15	0.20	0.28	0.38	0.44	0.50	0.57	0.63	0.76	0.82	0.86	0.01	0.02	0.02
	10000	0.08	0.15	0.20	0.28	0.39	0.45	0.51	0.58	0.64	0.77	0.82	0.86	0.01	0.02	0.02
	10300	0.08	0.15	0.21	0.29	0.40	0.46	0.52	0.59	0.65	0.77	0.83	0.86	0.01	0.02	0.02
	10600	0.08	0.15	0.21	0.30	0.40	0.47	0.53	0.60	0.66	0.78	0.83	0.86	0.01	0.02	0.02
	10900	0.08	0.16	0.21	0.30	0.41	0.48	0.54	0.61	0.67	0.79	0.84	0.86	0.01	0.02	0.02
	11500	0.08	0.16	0.22	0.32	0.43	0.49	0.56	0.63	0.69	0.80	0.84	0.84	0.02	0.02	0.03
	12100	0.09	0.17	0.23	0.33	0.44	0.51	0.58	0.65	0.70	0.81	0.83	0.82	0.02	0.02	0.03
	12500	0.09	0.17	0.24	0.34	0.45	0.52	0.59	0.66	0.71	0.81	0.83	0.80	0.02	0.02	0.03

Where $v > 60$ m/s, please consult our Applications Engineers!

⑩

⑳

③①

④①

v [m/s]

PROFILE PJ

POWER RATING P_N [kW] PER RIP FOR $\beta = 180^\circ$

AND $L_b = 1016$ mm



Table 6

v [m/s]	n_k [rpm]	Effective diameter of small pulley d_{sk} [mm]															Arc of contact correction factor [kW] per rib for speed ratio i			
		20	25	31,5	35,5	40	45	50	63	71	80	90	100	112	125	140	160	1.01 to 1.05	1.06 to 1.26	1.27 to 1.57
2	700	0.04	0.05	0.07	0.08	0.10	0.11	0.13	0.16	0.18	0.21	0.24	0.26	0.30	0.33	0.37	0.42			0.01
	950	0.05	0.07	0.09	0.11	0.13	0.14	0.16	0.21	0.24	0.28	0.31	0.35	0.39	0.44	0.49	0.56			0.01
	1450	0.06	0.09	0.13	0.15	0.18	0.21	0.24	0.31	0.35	0.40	0.45	0.51	0.57	0.63	0.71	0.81	0.01	0.01	0.01
	2850	0.11	0.16	0.23	0.28	0.32	0.38	0.43	0.56	0.64	0.72	0.82	0.91	1.02	1.14	1.27	1.43	0.01	0.02	0.02
	100	0.01	0.01	0.01	0.02	0.02	0.02	0.02	0.03	0.03	0.04	0.04	0.05	0.05	0.06	0.06	0.07			
	300	0.02	0.03	0.03	0.04	0.05	0.05	0.06	0.08	0.09	0.10	0.11	0.12	0.14	0.16	0.17	0.20			
	500	0.03	0.04	0.05	0.06	0.07	0.08	0.09	0.12	0.14	0.16	0.18	0.20	0.22	0.25	0.27	0.31			
	700	0.04	0.05	0.07	0.08	0.10	0.11	0.13	0.16	0.18	0.21	0.24	0.26	0.30	0.33	0.37	0.42			
	900	0.04	0.06	0.09	0.10	0.12	0.14	0.16	0.20	0.23	0.26	0.30	0.33	0.37	0.42	0.46	0.53			0.01
	1100	0.05	0.07	0.10	0.12	0.14	0.16	0.19	0.24	0.28	0.31	0.36	0.40	0.44	0.50	0.56	0.63		0.01	0.01
	1200	0.05	0.08	0.11	0.13	0.15	0.18	0.20	0.26	0.30	0.34	0.38	0.43	0.48	0.54	0.60	0.68		0.01	0.01
	1300	0.06	0.09	0.12	0.14	0.16	0.19	0.22	0.28	0.32	0.36	0.41	0.46	0.52	0.58	0.64	0.73	0.01	0.01	0.01
	1400	0.06	0.09	0.13	0.15	0.18	0.20	0.23	0.30	0.34	0.39	0.44	0.49	0.55	0.62	0.69	0.78	0.01	0.01	0.01
	1500	0.07	0.10	0.14	0.16	0.19	0.22	0.24	0.32	0.36	0.41	0.47	0.52	0.59	0.65	0.73	0.83	0.01	0.01	0.01
	1600	0.07	0.10	0.14	0.17	0.20	0.23	0.26	0.34	0.38	0.44	0.49	0.55	0.62	0.69	0.77	0.88	0.01	0.01	0.01
	1700	0.07	0.11	0.15	0.18	0.21	0.24	0.27	0.36	0.41	0.46	0.52	0.58	0.65	0.73	0.82	0.93	0.01	0.01	0.01
	1800	0.08	0.11	0.16	0.19	0.22	0.25	0.29	0.37	0.43	0.48	0.55	0.61	0.69	0.77	0.86	0.98	0.01	0.01	0.01
	1900	0.08	0.12	0.17	0.20	0.23	0.26	0.30	0.39	0.45	0.51	0.58	0.64	0.72	0.80	0.90	1.02	0.01	0.01	0.01
	2000	0.08	0.12	0.17	0.20	0.24	0.28	0.31	0.41	0.47	0.53	0.60	0.67	0.75	0.84	0.94	1.07	0.01	0.01	0.01
	2100	0.08	0.13	0.18	0.21	0.25	0.29	0.33	0.43	0.49	0.56	0.63	0.70	0.79	0.88	0.98	1.11	0.01	0.01	0.02
	2200	0.09	0.13	0.19	0.22	0.26	0.30	0.34	0.45	0.51	0.58	0.65	0.73	0.82	0.91	1.02	1.16	0.01	0.01	0.02
	2300	0.09	0.14	0.19	0.23	0.27	0.31	0.35	0.46	0.53	0.60	0.68	0.76	0.85	0.95	1.06	1.20	0.01	0.01	0.02
	2400	0.09	0.14	0.20	0.24	0.28	0.32	0.37	0.48	0.55	0.62	0.71	0.79	0.88	0.98	1.10	1.24	0.01	0.01	0.02
	2500	0.10	0.15	0.21	0.25	0.29	0.34	0.38	0.50	0.57	0.65	0.73	0.82	0.91	1.02	1.14	1.29	0.01	0.01	0.02
	2600	0.10	0.15	0.22	0.26	0.30	0.35	0.39	0.52	0.59	0.67	0.76	0.84	0.94	1.05	1.17	1.33	0.01	0.01	0.02
	2700	0.10	0.16	0.22	0.26	0.31	0.36	0.41	0.53	0.61	0.69	0.78	0.87	0.98	1.09	1.21	1.37	0.01	0.02	0.02
	2800	0.11	0.16	0.23	0.27	0.32	0.37	0.42	0.55	0.63	0.71	0.81	0.90	1.01	1.12	1.25	1.41	0.01	0.02	0.02
	2900	0.11	0.17	0.24	0.28	0.33	0.38	0.43	0.57	0.65	0.73	0.83	0.93	1.04	1.15	1.28	1.45	0.01	0.02	0.02
	3000	0.11	0.17	0.24	0.29	0.34	0.39	0.45	0.58	0.67	0.76	0.86	0.95	1.07	1.19	1.32	1.49	0.01	0.02	0.02
	3100	0.11	0.17	0.25	0.30	0.35	0.40	0.46	0.60	0.68	0.78	0.88	0.98	1.10	1.22	1.35	1.53	0.01	0.02	0.02
3200	0.12	0.18	0.26	0.30	0.36	0.41	0.47	0.62	0.70	0.80	0.90	1.01	1.13	1.25	1.39	1.56	0.01	0.02	0.02	
3300	0.12	0.18	0.26	0.31	0.37	0.43	0.48	0.63	0.72	0.82	0.93	1.03	1.15	1.28	1.42	1.60	0.01	0.02	0.02	
3400	0.12	0.19	0.27	0.32	0.38	0.44	0.50	0.65	0.74	0.84	0.95	1.06	1.18	1.31	1.46	1.64	0.01	0.02	0.02	
3500	0.13	0.19	0.28	0.33	0.38	0.45	0.51	0.67	0.76	0.86	0.97	1.08	1.21	1.34	1.49	1.67	0.01	0.02	0.03	
3600	0.13	0.20	0.28	0.34	0.39	0.46	0.52	0.68	0.78	0.88	1.00	1.11	1.24	1.37	1.52	1.71	0.01	0.02	0.03	
3700	0.13	0.20	0.29	0.34	0.40	0.47	0.53	0.70	0.80	0.90	1.02	1.13	1.27	1.40	1.55	1.74	0.02	0.02	0.03	
3800	0.13	0.21	0.30	0.35	0.41	0.48	0.55	0.71	0.81	0.92	1.04	1.16	1.29	1.43	1.59	1.77	0.02	0.02	0.03	
3900	0.14	0.21	0.30	0.36	0.42	0.49	0.56	0.73	0.83	0.94	1.07	1.18	1.32	1.46	1.62	1.80	0.02	0.02	0.03	
4000	0.14	0.21	0.31	0.37	0.43	0.50	0.57	0.75	0.85	0.96	1.09	1.21	1.35	1.49	1.65	1.84	0.02	0.02	0.03	
4100	0.14	0.22	0.32	0.37	0.44	0.51	0.58	0.76	0.87	0.98	1.11	1.23	1.37	1.52	1.68	1.87	0.02	0.02	0.03	
4200	0.14	0.22	0.32	0.38	0.45	0.52	0.59	0.78	0.89	1.00	1.13	1.26	1.40	1.55	1.70	1.90	0.02	0.02	0.03	
4300	0.15	0.23	0.33	0.39	0.46	0.53	0.61	0.79	0.90	1.02	1.15	1.28	1.42	1.57	1.73	1.92	0.02	0.02	0.03	
4400	0.15	0.23	0.33	0.40	0.47	0.54	0.62	0.81	0.92	1.04	1.18	1.30	1.45	1.60	1.76	1.95	0.02	0.02	0.03	
4500	0.15	0.23	0.34	0.40	0.48	0.55	0.63	0.82	0.94	1.06	1.20	1.33	1.47	1.63	1.79	1.98	0.02	0.03	0.03	
4600	0.15	0.24	0.35	0.41	0.48	0.56	0.64	0.84	0.95	1.08	1.22	1.35	1.50	1.65	1.81	2.00	0.02	0.03	0.03	
4700	0.16	0.24	0.35	0.42	0.49	0.57	0.65	0.85	0.97	1.10	1.24	1.37	1.52	1.68	1.84	2.03	0.02	0.03	0.03	
4800	0.16	0.25	0.36	0.43	0.50	0.58	0.66	0.87	0.99	1.12	1.26	1.39	1.55	1.70	1.86	2.05	0.02	0.03	0.03	
4900	0.16	0.25	0.37	0.43	0.51	0.59	0.68	0.88	1.01	1.14	1.28	1.42	1.57	1.72	1.89	2.07	0.02	0.03	0.04	
5000	0.16	0.26	0.37	0.44	0.52	0.60	0.69	0.90	1.02	1.16	1.30	1.44	1.59	1.75	1.91	2.09	0.02	0.03	0.04	
5100	0.17	0.26	0.38	0.45	0.53	0.61	0.70	0.91	1.04	1.17	1.32	1.46	1.62	1.77	1.93	2.12	0.01	0.02	0.03	
5200	0.17	0.26	0.38	0.46	0.54	0.62	0.71	0.93	1.05	1.19	1.34	1.48	1.64	1.79	1.95	2.13	0.01	0.02	0.03	
5300	0.17	0.27	0.39	0.46	0.55	0.63	0.72	0.94	1.07	1.21	1.36	1.50	1.66	1.82	1.98	2.15	0.01	0.02	0.03	
5400	0.17	0.27	0.40	0.47	0.55	0.64	0.73	0.96	1.09	1.23	1.38	1.52	1.68	1.84	2.00	2.17	0.01	0.02	0.03	
5500	0.18	0.28	0.40	0.48	0.56	0.65	0.74	0.97	1.10	1.25	1.40	1.54	1.70	1.86	2.02	2.19	0.01	0.02	0.03	
5600	0.18	0.28	0.41	0.48	0.57	0.66	0.76	0.98	1.12	1.26	1.42	1.56	1.72	1.88	2.03	2.20	0.01	0.02	0.03	
5700	0.18	0.28	0.41	0.49	0.58	0.67	0.77	1.00	1.13	1.28	1.44	1.58	1.74	1.90	2.05	2.22	0.01	0.02	0.03	
5800	0.18	0.29	0.42	0.50	0.59	0.68	0.78	1.01	1.15	1.30	1.45	1.60	1.76	1.92	2.07	2.23	0.01	0.02	0.03	
6000	0.19	0.29	0.43	0.51	0.60	0.70	0.80	1.04	1.18	1.33	1.49	1.64	1.80	1.95	2.10	2.25	0.01	0.02	0.03	
6200	0.19	0.30	0.44	0.53	0.62	0.72	0.82	1.07	1.21	1.36	1.52	1.67	1.83	1.99	2.13	2.27	0.01	0.03	0.04	
6400	0.20	0.31	0.45	0.54	0.64	0.74	0.84	1.09	1.24	1.40	1.56	1.71	1.87	2.02	2.16	2.28	0.01	0.03	0.04	
6600	0.20	0.32	0.47	0.55	0.65	0.76	0.86	1.12	1.27	1.43	1.59	1.74	1.90	2.05	2.18	2.28	0.01	0.03	0.04	
6800	0.20	0.32	0.48	0.57	0.67	0.78	0.88	1.15	1.30	1.46	1.62	1.77	1.93	2.07	2.20	2.29	0.01	0.03	0.04	
7000	0.21	0.33	0.49	0.58	0.68	0.79	0.90	1.17	1.32	1.49	1.65	1.80	1.96	2.10	2.21	2.28	0.01	0.03	0.04	
7200	0.21	0.34	0.50	0.59	0.70	0.81	0.92	1.20	1.35	1.52	1.68	1.83	1.98	2.12	2.22	2.27	0.01	0.03	0.04	
7400	0.22	0.35	0.51	0.61	0.71	0.83	0.94	1.												

PROFILE PL

POWER RATING P_N [kW] PER RIB FOR $\beta = 180^\circ$

AND $L_b = 2096$ mm



Table 8

v [m/s]	n_k [rpm]	Effective diameter of small pulley d_{sk} [mm]															Arc of contact correction factor [kW] per rib for speed ratio i				
		76	80	90	100	112	125	140	160	180	200	224	250	280	315	355	400	1.01 to 1.05	1.06 to 1.26	1.27 to 1.57	> 1.57
5	700	0.49	0.53	0.64	0.74	0.87	1.00	1.15	1.34	1.54	1.73	1.96	2.20	2.48	2.80	3.16	3.55	0.01	0.03	0.04	0.06
	950	0.63	0.69	0.83	0.96	1.12	1.30	1.49	1.75	2.01	2.26	2.56	2.87	3.23	3.64	4.09	4.58	0.01	0.04	0.06	0.08
	1450	0.89	0.97	1.17	1.37	1.60	1.85	2.14	2.51	2.88	3.23	3.65	4.09	4.58	5.12	5.71	6.32	0.02	0.07	0.09	0.12
	2850	1.50	1.65	2.00	2.35	2.76	3.19	3.67	4.28	4.85	5.38	5.96	6.51	7.04	7.51	7.82	7.84	0.03	0.13	0.18	0.23
	100	0.10	0.10	0.12	0.14	0.16	0.18	0.21	0.24	0.28	0.31	0.35	0.39	0.44	0.50	0.56	0.63			0.01	0.01
	200	0.17	0.19	0.22	0.25	0.29	0.34	0.38	0.45	0.51	0.57	0.65	0.73	0.82	0.92	1.04	1.17			0.01	0.01
	300	0.24	0.26	0.31	0.36	0.42	0.48	0.55	0.64	0.73	0.82	0.93	1.04	1.17	1.32	1.50	1.69			0.01	0.02
	400	0.31	0.34	0.40	0.46	0.53	0.61	0.70	0.82	0.94	1.06	1.20	1.35	1.52	1.71	1.93	2.18			0.02	0.03
	500	0.37	0.40	0.48	0.56	0.65	0.75	0.86	1.00	1.15	1.29	1.46	1.64	1.85	2.09	2.35	2.65	0.01	0.02	0.03	0.04
	600	0.43	0.47	0.56	0.65	0.76	0.87	1.00	1.18	1.35	1.51	1.71	1.93	2.17	2.45	2.76	3.11	0.01	0.03	0.04	0.05
	700	0.49	0.53	0.64	0.74	0.87	1.00	1.15	1.34	1.54	1.73	1.96	2.20	2.48	2.80	3.16	3.55	0.01	0.03	0.04	0.06
	800	0.55	0.60	0.71	0.83	0.97	1.12	1.29	1.51	1.73	1.95	2.20	2.48	2.79	3.14	3.54	3.97	0.01	0.04	0.05	0.06
	900	0.61	0.66	0.79	0.92	1.07	1.24	1.42	1.67	1.92	2.16	2.44	2.74	3.08	3.47	3.91	4.38	0.01	0.04	0.06	0.07
	1000	0.66	0.72	0.86	1.00	1.17	1.35	1.56	1.83	2.10	2.36	2.67	3.00	3.37	3.80	4.27	4.78	0.01	0.05	0.06	0.08
	1100	0.71	0.78	0.93	1.09	1.27	1.47	1.69	1.99	2.28	2.56	2.90	3.25	3.65	4.11	4.61	5.15	0.01	0.05	0.07	0.09
	1200	0.76	0.83	1.00	1.17	1.37	1.58	1.82	2.14	2.45	2.76	3.12	3.50	3.93	4.41	4.94	5.51	0.01	0.06	0.08	0.10
	1300	0.82	0.89	1.07	1.25	1.46	1.69	1.95	2.29	2.62	2.95	3.33	3.74	4.19	4.70	5.26	5.85	0.01	0.06	0.08	0.11
	1400	0.87	0.94	1.14	1.33	1.56	1.80	2.08	2.44	2.79	3.14	3.55	3.97	4.45	4.98	5.56	6.16	0.02	0.07	0.09	0.11
	1500	0.91	1.00	1.20	1.41	1.65	1.91	2.20	2.58	2.96	3.32	3.75	4.20	4.70	5.25	5.85	6.46	0.02	0.07	0.10	0.12
	1600	0.96	1.05	1.27	1.49	1.74	2.01	2.32	2.73	3.12	3.50	3.95	4.42	4.94	5.51	6.12	6.74	0.02	0.07	0.10	0.13
1700	1.01	1.10	1.33	1.56	1.83	2.12	2.44	2.87	3.28	3.68	4.15	4.63	5.17	5.75	6.37	6.99	0.02	0.08	0.11	0.14	
1800	1.06	1.15	1.40	1.64	1.92	2.22	2.56	3.00	3.43	3.85	4.34	4.84	5.39	5.99	6.61	7.22	0.02	0.08	0.12	0.15	
1900	1.10	1.21	1.46	1.71	2.00	2.32	2.68	3.14	3.59	4.02	4.52	5.04	5.60	6.21	6.82	7.42	0.02	0.09	0.12	0.15	
2000	1.15	1.25	1.52	1.78	2.09	2.42	2.79	3.27	3.73	4.18	4.70	5.23	5.80	6.41	7.02	7.59	0.02	0.09	0.13	0.16	
2100	1.19	1.30	1.58	1.85	2.17	2.52	2.90	3.40	3.88	4.34	4.87	5.41	5.99	6.60	7.20	7.74	0.02	0.10	0.13	0.17	
2200	1.24	1.35	1.64	1.92	2.26	2.61	3.01	3.53	4.02	4.50	5.04	5.59	6.17	6.78	7.36	7.86	0.02	0.10	0.14	0.18	
2300	1.28	1.40	1.70	1.99	2.34	2.70	3.12	3.65	4.16	4.65	5.20	5.75	6.34	6.94	7.49	7.95	0.03	0.11	0.15	0.19	
2400	1.32	1.45	1.76	2.06	2.42	2.80	3.22	3.77	4.29	4.79	5.35	5.91	6.50	7.08	7.61	8.00	0.03	0.11	0.15	0.19	
2500	1.36	1.49	1.81	2.13	2.50	2.89	3.33	3.89	4.42	4.93	5.50	6.06	6.64	7.21	7.70	8.03	0.03	0.12	0.16	0.20	
10	2600	1.40	1.54	1.87	2.19	2.57	2.98	3.43	4.00	4.55	5.06	5.64	6.20	6.77	7.32	7.76	8.02	0.03	0.12	0.17	0.21
	2700	1.44	1.58	1.92	2.26	2.65	3.06	3.52	4.11	4.67	5.19	5.77	6.33	6.89	7.41	7.81	7.98	0.03	0.13	0.17	0.22
	2800	1.48	1.63	1.98	2.32	2.72	3.15	3.62	4.22	4.79	5.32	5.90	6.45	7.00	7.48	7.82	7.90	0.03	0.13	0.18	0.23
	2900	1.52	1.67	2.03	2.38	2.80	3.23	3.72	4.33	4.90	5.43	6.01	6.56	7.09	7.54	7.81		0.03	0.14	0.19	0.23
	3000	1.56	1.71	2.08	2.45	2.87	3.31	3.81	4.43	5.01	5.55	6.13	6.67	7.17	7.57	7.77		0.03	0.14	0.19	0.24
	3100	1.60	1.75	2.13	2.51	2.94	3.39	3.90	4.53	5.12	5.65	6.23	6.76	7.23	7.59	7.71		0.03	0.14	0.20	0.25
	3200	1.63	1.79	2.18	2.56	3.01	3.47	3.98	4.62	5.22	5.75	6.32	6.83	7.28	7.58			0.04	0.15	0.20	0.26
	3300	1.67	1.83	2.23	2.62	3.08	3.55	4.07	4.72	5.31	5.85	6.41	6.90	7.31	7.56			0.04	0.15	0.21	0.27
	3400	1.71	1.87	2.28	2.68	3.14	3.62	4.15	4.81	5.40	5.94	6.49	6.96	7.33	7.51			0.04	0.16	0.22	0.28
	3500	1.74	1.91	2.33	2.74	3.21	3.69	4.23	4.89	5.49	6.02	6.56	7.00	7.33	7.44			0.04	0.16	0.22	0.28
3600	1.78	1.95	2.38	2.79	3.27	3.77	4.31	4.97	5.57	6.09	6.62	7.04	7.32	7.34			0.04	0.17	0.23	0.29	
3700	1.81	1.99	2.42	2.84	3.33	3.83	4.38	5.05	5.65	6.16	6.67	7.06	7.29				0.04	0.17	0.24	0.30	
3800	1.84	2.02	2.47	2.90	3.39	3.90	4.45	5.13	5.72	6.23	6.71	7.07	7.24				0.04	0.18	0.24	0.31	
3900	1.87	2.06	2.51	2.95	3.45	3.96	4.52	5.20	5.78	6.28	6.74	7.06	7.17				0.04	0.18	0.25	0.32	
4000	1.91	2.09	2.55	3.00	3.51	4.03	4.59	5.26	5.85	6.33	6.76	7.04	7.09				0.05	0.19	0.26	0.32	
4100	1.94	2.13	2.60	3.05	3.56	4.09	4.65	5.32	5.90	6.37	6.78	7.01					0.05	0.19	0.26	0.33	
4200	1.97	2.16	2.64	3.09	3.61	4.15	4.71	5.38	5.95	6.40	6.78	6.97					0.05	0.20	0.27	0.34	
4300	2.00	2.19	2.68	3.14	3.67	4.20	4.77	5.44	5.99	6.43	6.77	6.91					0.05	0.20	0.28	0.35	
4400	2.03	2.23	2.72	3.18	3.72	4.25	4.82	5.49	6.03	6.45	6.75	6.83					0.05	0.21	0.28	0.36	
4500	2.05	2.26	2.75	3.23	3.76	4.31	4.88	5.53	6.06	6.46	6.73	6.74					0.05	0.21	0.29	0.36	
4600	2.08	2.29	2.79	3.27	3.81	4.36	4.92	5.58	6.09	6.46	6.68						0.05	0.22	0.29	0.37	
4700	2.11	2.32	2.83	3.31	3.86	4.40	4.97	5.61	6.11	6.45	6.63						0.05	0.22	0.30	0.38	
4800	2.13	2.35	2.86	3.35	3.90	4.45	5.01	5.64	6.13	6.44	6.57						0.05	0.22	0.31	0.39	
4900	2.16	2.37	2.89	3.39	3.94	4.49	5.05	5.67	6.13	6.42	6.50						0.06	0.23	0.31	0.40	
5000	2.18	2.40	2.93	3.42	3.98	4.53	5.09	5.70	6.13	6.38	6.41						0.06	0.23	0.32	0.40	
5100	2.21	2.43	2.96	3.46	4.02	4.57	5.12	5.71	6.13	6.34							0.06	0.24	0.33	0.41	
5200	2.23	2.45	2.99	3.49	4.05	4.60	5.15	5.73	6.12	6.29							0.06	0.24	0.33	0.42	
5300	2.25	2.48	3.02	3.53	4.09	4.63	5.17	5.74	6.10	6.23							0.06	0.25	0.34	0.43	
5400	2.28	2.50	3.05	3.56	4.12	4.66	5.20	5.74	6.07	6.17							0.06	0.25	0.35	0.44	
5500	2.30	2.53	3.07	3.59	4.15	4.69	5.22	5.74	6.04	6.09							0.06	0.26	0.35	0.45	
5600	2.32	2.55	3.10	3.62	4.18	4.71	5.23	5.73	6.00								0.06	0.26	0.36	0.45	
5700	2.34	2.57	3.13	3.64	4.20	4.74	5.24	5.72	5.95								0.06	0.27	0.36	0.46	
5800	2.35	2.59	3.15	3.67	4.23	4.75	5.25	5.70									0.07	0.27	0.37	0.47	
5900	2.37	2.61	3.17	3.69	4.25	4.77	5.25	5.68									0.07	0.28	0.38	0.48	
6000	2.39	2.63	3.19	3.71	4.27	4.78	5.25										0.07	0.28	0.38	0.49	

Where $v > 40$ m/s,
please consult our
Applications
Engineers!

3

PROFILE PM

POWER RATING P_N [kW] PER RIB FOR $\beta = 180^\circ$

AND $L_b = 4089$ mm



Table 9

v [m/s]	n_k [rpm]	Effective diameter of small pulley d_{bk} [mm]														Arc of contact correction factor [kW] per rib for speed ratio i					
		180	190	200	224	250	280	315	355	400	450	500	560	630	710	800	1000	1.01 to 1.05	1.06 to 1.26	1.27 to 1.57	> 1.57
5	700	3.51	3.83	4.16	4.93	5.75	6.68	7.74	8.93	10.22	11.60	12.92	14.43	16.07	17.78	19.47	22.23	0.06	0.24	0.33	0.42
	950	4.46	4.88	5.30	6.29	7.34	8.52	9.85	11.31	12.86	14.48	15.97	17.58	19.20	20.65	21.74	21.79	0.08	0.33	0.45	0.56
	1450	6.06	6.65	7.22	8.57	9.96	11.47	13.11	14.80	16.43	17.90	18.97	19.66	19.57	18.16	14.71		0.12	0.50	0.68	0.86
	2850	8.24	8.97	9.64	11.01	12.10	12.77	12.69	11.34	8.03	1.86							0.24	0.98	1.34	1.69
	100	0.70	0.76	0.81	0.95	1.09	1.26	1.45	1.66	1.90	2.17	2.43	2.74	3.10	3.50	3.95	4.93	0.01	0.03	0.05	0.06
	200	1.25	1.36	1.46	1.72	1.99	2.30	2.66	3.06	3.51	4.00	4.49	5.07	5.73	6.48	7.31	9.10	0.02	0.07	0.09	0.12
	300	1.76	1.91	2.06	2.43	2.82	3.27	3.78	4.36	5.00	5.71	6.40	7.22	8.16	9.22	10.37	12.82	0.02	0.10	0.14	0.18
	400	2.23	2.43	2.62	3.10	3.60	4.18	4.84	5.59	6.42	7.32	8.20	9.24	10.42	11.73	13.15	16.08	0.03	0.14	0.19	0.24
	500	2.67	2.92	3.16	3.73	4.35	5.05	5.86	6.76	7.75	8.83	9.89	11.12	12.50	14.01	15.62	18.79	0.04	0.17	0.23	0.30
	600	3.10	3.39	3.67	4.35	5.07	5.88	6.82	7.87	9.02	10.26	11.46	12.85	14.39	16.04	17.74	20.87	0.05	0.21	0.28	0.36
	700	3.51	3.83	4.16	4.93	5.75	6.68	7.74	8.93	10.22	11.60	12.92	14.43	16.07	17.78	19.47	22.23	0.06	0.24	0.33	0.42
	800	3.90	4.27	4.63	5.49	6.41	7.44	8.62	9.92	11.34	12.83	14.25	15.83	17.51	19.20	20.75	22.76	0.07	0.27	0.38	0.48
	900	4.27	4.68	5.08	6.03	7.04	8.17	9.45	10.86	12.38	13.96	15.43	17.05	18.70	20.26	21.55	22.37	0.07	0.31	0.42	0.53
	1000	4.63	5.07	5.51	6.55	7.64	8.86	10.24	11.74	13.33	14.97	16.47	18.07	19.62	20.94	21.79		0.08	0.34	0.47	0.59
	1100	4.98	5.45	5.93	7.04	8.21	9.51	10.97	12.55	14.20	15.87	17.35	18.86	20.22	21.19	21.44		0.09	0.38	0.52	0.65
1200	5.31	5.82	6.32	7.51	8.75	10.12	11.65	13.28	14.97	16.63	18.05	19.42	20.50	20.97			0.10	0.41	0.56	0.71	
1300	5.62	6.16	6.70	7.95	9.26	10.70	12.28	13.95	15.64	17.25	18.57	19.72	20.42	20.26			0.11	0.45	0.61	0.77	
1400	5.92	6.49	7.05	8.37	9.73	11.23	12.85	14.53	16.20	17.73	18.89	19.75	19.95				0.12	0.48	0.66	0.83	
1500	6.20	6.80	7.39	8.76	10.18	11.71	13.36	15.04	16.64	18.04	18.99	19.49					0.12	0.51	0.70	0.89	
1600	6.47	7.09	7.71	9.13	10.58	12.15	13.80	15.45	16.97	18.19	18.87	18.91					0.13	0.55	0.75	0.95	
1700	6.72	7.36	8.00	9.47	10.96	12.54	14.18	15.78	17.17	18.16	18.51						0.14	0.58	0.80	1.01	
1800	6.95	7.62	8.27	9.78	11.29	12.88	14.49	16.00	17.23	17.94	17.90						0.15	0.62	0.85	1.07	
1900	7.16	7.85	8.52	10.06	11.58	13.16	14.73	16.13	17.15	17.53							0.16	0.65	0.89	1.13	
2000	7.36	8.07	8.75	10.30	11.84	13.39	14.89	16.15	16.92	16.91							0.17	0.69	0.94	1.19	
2100	7.54	8.26	8.96	10.52	12.05	13.56	14.97	16.06	16.54								0.17	0.72	0.99	1.25	
2200	7.70	8.43	9.13	10.71	12.21	13.67	14.97	15.85	16.00								0.18	0.76	1.03	1.31	
2300	7.84	8.58	9.29	10.86	12.33	13.72	14.88	15.52	15.29								0.19	0.79	1.08	1.37	
2400	7.96	8.70	9.41	10.97	12.41	13.71	14.70	15.07									0.20	0.82	1.13	1.43	
2500	8.06	8.81	9.51	11.05	12.43	13.62	14.43	14.48									0.21	0.86	1.17	1.48	
2600	8.14	8.88	9.59	11.09	12.40	13.47	14.06	13.76									0.22	0.89	1.22	1.54	
2700	8.20	8.94	9.63	11.09	12.32	13.25	13.59										0.22	0.93	1.27	1.60	
2800	8.23	8.96	9.64	11.05	12.19	12.95	13.02										0.23	0.96	1.32	1.66	
2900	8.24	8.96	9.63	10.97	12.00	12.57	12.34										0.24	1.00	1.36	1.72	
3000	8.23	8.93	9.58	10.85	11.75	12.12											0.25	1.03	1.41	1.78	
3100	8.19	8.88	9.50	10.68	11.44	11.58											0.26	1.06	1.46	1.84	
3200	8.13	8.79	9.38	10.46	11.07	10.96											0.26	1.10	1.50	1.90	

Where $v > 30$ m/s,
please consult our
Applications
Engineers!

v [m/s]

SPECIAL DRIVES

V-FLAT DRIVE



The V-flat drive utilises a ribbed belt pulley and a flat faced pulley. Under certain conditions, this type of drive can be used for drives which are subject to shock loadings or have high moments of inertia. Because flywheels or flat pulleys are quite often already fitted, drive costs can be reduced. When

converting a flat belt drive to a V-Flat drive, it is usually economical to continue to use the large flat pulley.

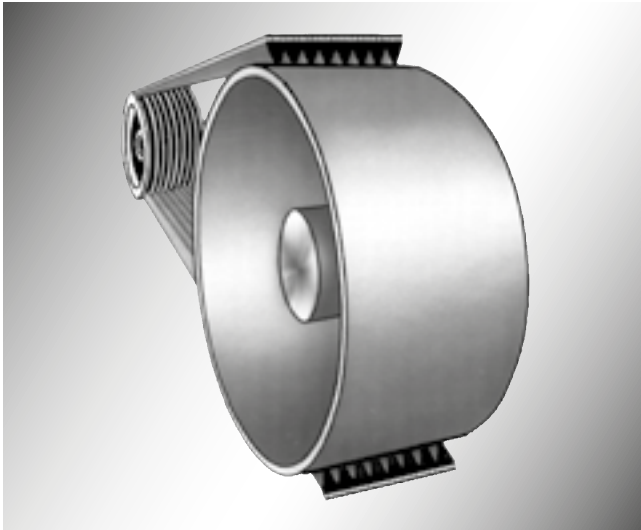

- a = Drive centre distance [mm]
- b = Flat pulley face width [mm]
- b_2 = Ribbed belt pulley face width [mm]
- D_a = Flat pulley outside diameter [mm]
- D_z = Allowance for determining the theoretical diameter [mm]
- d_b = Effective diameter of ribbed belt pulley [mm]
- f = Allowance for determining the flat pulley face width [mm]
- h = Crown height per 100 mm of pulley face width [mm]
- i = Speed ratio
- L_{bth} = Calculated belt effective length [mm]

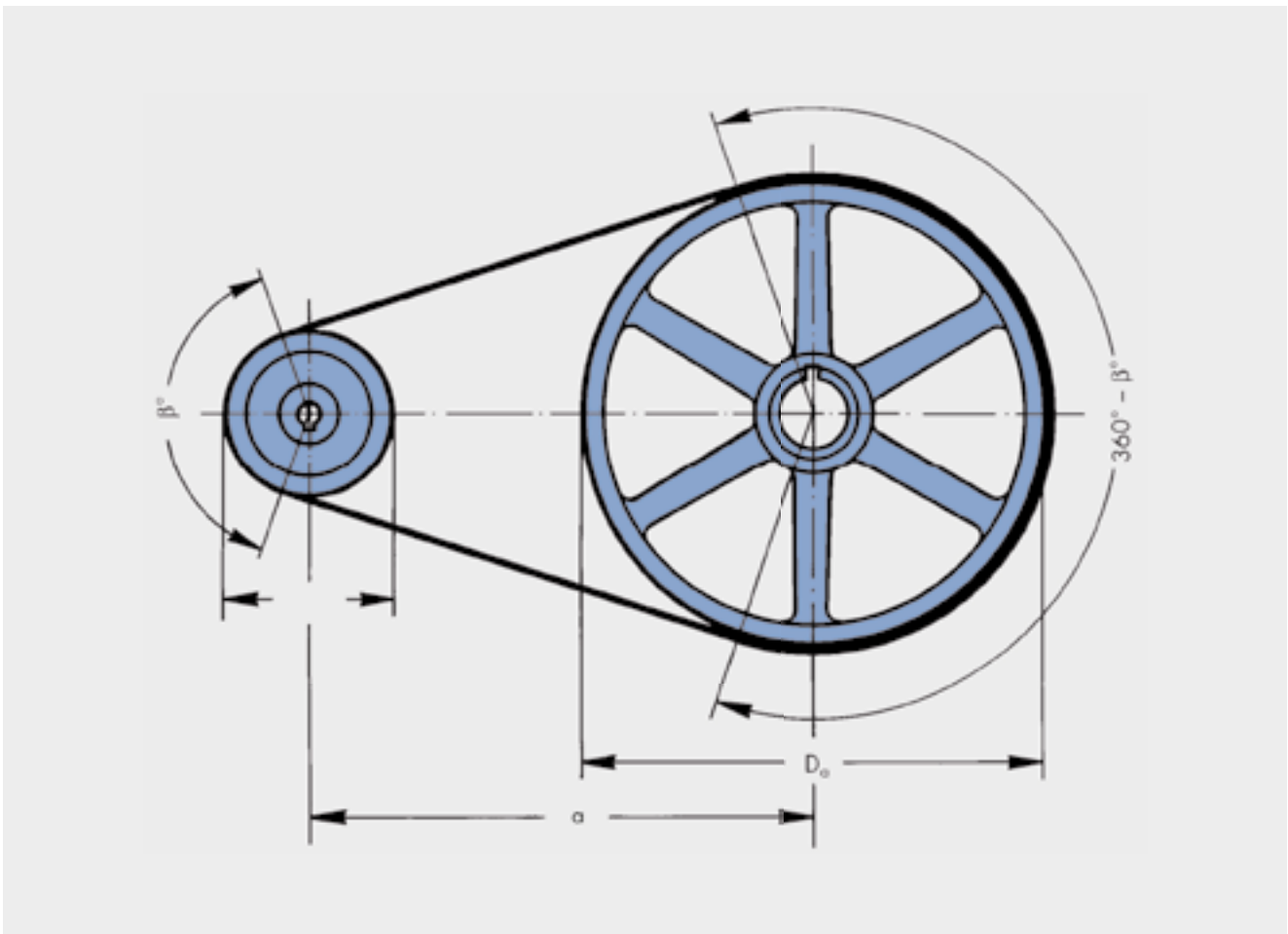

SPECIAL DRIVES

V-FLAT DRIVE



Calculation of V-Flat Drives

The calculation for a V-flat drive is undertaken in the same manner as shown on pages 22 to 24. The following important requirements must be checked so as to ensure a reliable and efficient V-flat drive.

- The small pulley must always be a grooved pulley.
- The V-flat drive is particularly economical when

$$K = \frac{D_a - d_b}{a} \text{ lies between } 0.5 \text{ and } 1.15.$$

The ideal drive is achieved when $K = 0.85$. If the "K" factor falls outside the recommended range, it is then more economical to use a normal ribbed belt drive with grooved pulleys.

- The following recommendations are made based upon the above requirements:

Speed ratio	$i = \frac{D_a + D_z}{d_b + 2 h_b} \geq 3$
Drive centre distance	$a_{all} \geq D_a$
	$a = \frac{D_a - d_b}{0.85}$
K factor	$K = \frac{D_a - d_b}{a}$
	$K_{all} \text{ } 0.5 \text{ to } 1.15$

- When calculating the number of ribs and the belt tension, care must be taken to ensure that a **special arc of contact correction factor c_1** as detailed in the following table 10 is applied.

In addition to the drive design on pages 22 to 24, the static belt tension for V-flat drives must be calculated with the adjacent formula.

Table 10: Arc of Contact Correction Factor c_1 (for V-Flat Drives Only)

$K = \frac{D_a - d_b}{a}$	$\beta \approx$	c_1
0	180°	0.75
0.07	176°	0.76
0.15	170°	0.77
0.22	167°	0.79
0.29	163°	0.79
0.35	160°	0.80
0.40	156°	0.81
0.45	153°	0.81
0.50	150°	0.82
0.57	146°	0.83
0.64	143°	0.84
0.70	140°	0.85
0.75	137°	0.85
0.80	134°	0.86
0.85	130°	0.86
0.92	125°	0.84
1.00	120°	0.82
1.07	115°	0.80
1.15	110°	0.78
1.21	106°	0.77
1.30	100°	0.73
1.36	96°	0.72
1.45	90°	0.70

The length calculation is for the effective length L_b . Therefore, in order to obtain the theoretical calculation diameter, an allowance D_z must be added to the flat pulley outside diameter.

Table 11: Effective Line Difference h_b

Profile	PH	PJ	PK	PL	PM
h_b nominal dimension	0.80	1.25	1.60	3.50	5.00
D_z	1.60	2.70	3.50	6.50	11.00

Calculation of the effective length

$$L_{bth} \approx 2 a + 1.57 (d_b + D_a + D_z) + \frac{(D_a + D_z - d_b)^2}{4 a}$$

Formula:

Calculation of the static belt tension for V-flat drives

$$T = \frac{500 \cdot (2.25 - c_1) \cdot P_B}{c_1 \cdot z \cdot v} + k \cdot v^2$$

Tensioning/guide pulleys are ribbed or flat faced and do not transmit power within a drive system. Because they create additional bending stresses within the belt their use should be restricted to the following applications if possible:

- with fixed drive centres to produce the required belt tension and to provide for maximum belt stretch and wear
- as damping and guide rollers with long span lengths
- as guide rollers on drives where the pulleys are not all positioned in one plane
- as movable tensioners, to achieve a constant belt tension. This results in reduced maintenance and longer service life. The tension force is normally generated by springs, pneumatics or hydraulics.

If idler pulleys have to be used for the reasons mentioned above, the following criteria should be observed in drive design:

- position of the pulley in the belt span
- diameter
- shape
- the adjustment travel of the pulley, both for tensioning and retensioning the ribbed belts
- correction of the power rating per rib P_N

Idler Arrangement

Idlers can be used as inside or outside idlers. The end position of the idler must be based on the maximum belt stretch assumption. Flat pulleys, whether used inside or outside should be placed as far away as possible from the next grooved pulley that the ribbed belt will run onto. Misalignment of the idler and the pulley due to lateral movements on the flat pulley can largely be prevented as a result.

If the design conditions do not favour an outside idler, an inside idler is then generally more advantageous. Inside idler diameters can be smaller than outside idler diameters.

Inside idlers can be either grooved pulleys or flat pulleys. Inside idlers reduce the arc of contact on the loaded pulleys and hence also the arc of contact correction factor c_1 . When calculating the number of ribs, the arc of contact correction factor is to be selected at the point of the maximum belt extension (see table 14, page 34).

Ribbed belt pulleys are to be preferred as inside idlers on long spans as flat pulleys could permit the development of lateral vibration.

Outside idlers must always take the form of flat pulleys as they run on the top surface of the belt. They increase the arc of contact. Care must be taken however to ensure that the maximum possible belt stretch is taken up, and that contact with the opposite span is prevented.

Inside Idler

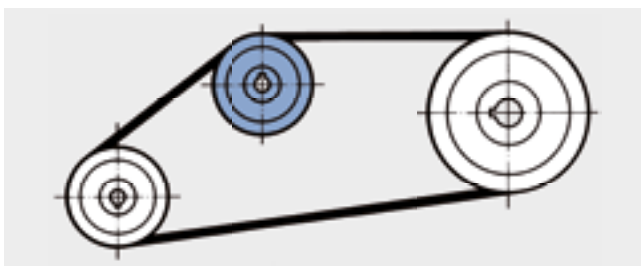

The diametrically opposed bending caused when outside idlers are used can lead to a reduction of the belt service life.

Idlers on the Tight/Slack Side

Both the theoretical power transmission formulae and actual practice have shown that wherever possible the idler should be placed on the slack side of the drive. This allows the idler tension force to be maintained at a considerably lower level. A spring loaded idler must not be used in a reversing drive because the tight and slack sides change continuously. Our engineers will be pleased to advise you about special problems regarding spring loaded idlers!

Minimum Diameter for Inside Idlers

Inside idler \geq the smallest driven pulley in the system

Minimum Diameter for Outside Idlers

Outside idler \geq 1.2 times the smallest loaded pulley in the system

Table 12: Minimum Diameter for Idlers

Profile	Minimum diameter of inside idler [mm]	Minimum diameter of outside idler [mm]
PH	20	40
PJ	25	50
PK	50	70
PL	100	150
PM	200	300

Failure to observe the minimum recommended idler diameter will impair the service life of the ribbed belts.

Idler Design

Ribbed belt pulleys used as idlers normally have standard groove dimensions. Flat pulleys should wherever possible be cylindrical, not crowned.

Outside Idler

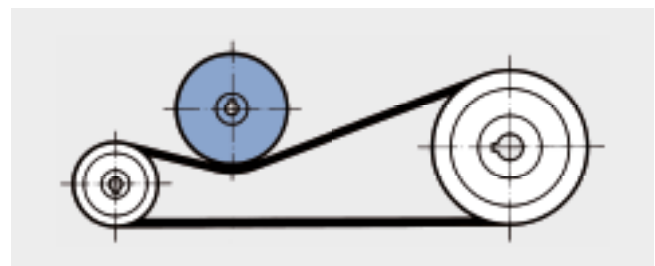

Drive Calculation

The length calculation and the determination of the number of ribs is undertaken as for two-pulley drives. Certain details must, however, be taken into account:

1. Calculate the ribbed belt length over two pulleys using the formula:

$$L_{bth} \approx 2 a + 1.57 (d_{bg} + d_{bk}) + \frac{(d_{bg} - d_{bk})^2}{4 a}$$

2. If the ribbed belt has to be fitted with a fixed drive centre distance, twice the allowance y should be added to the belt length L_{bth} (see table 3, page 19).

$$L_b = L_{bth} + 2 y$$

3. The next longest standard length L_{bSt} should then be selected.

A check should be made to determine whether the belt can be adequately tensioned with the idler in the outermost position. In this idler position, both the standard length L_{bSt} as well as double the allowance x must be taken up (see table 3, page 19).

$$L_b \text{ for idler end position} = L_{bSt} + 2 x$$

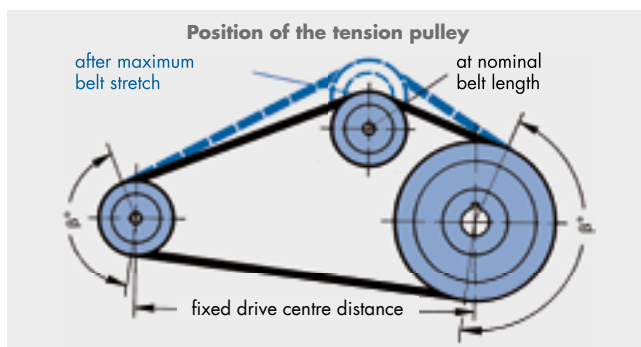

Number of Idlers

The application of idlers increases the bending stress in the ribbed belts. To avoid a reduction in belt service life, the idler correction factor c_4 must also be included in the calculation. This correction factor takes the number of idlers into consideration with the minimum diameter being maintained.

Table 13

Number of idlers	c_4
0	1.00
1	0.91
2	0.86
3	0.81

The nominal power rating P_N per rib is as previously based on the smallest **loaded pulley**.

In determining the arc of contact correction factor c_1 the **smallest contact angle of the loaded pulleys** which occurs at maximum belt extension must be used.

Table 14: Arc of Contact Correction Factor c_1

$\beta \approx$	c_1	$\beta \approx$	c_1
75°	0.78	175°	1.00
80°	0.82	180°	1.00
85°	0.84	185°	1.00
90°	0.85	190°	1.01
95°	0.87	195°	1.01
100°	0.89	200°	1.01
105°	0.90	205°	1.01
110°	0.91	210°	1.01
115°	0.92	215°	1.02
120°	0.93	220°	1.02
125°	0.94	225°	1.02
130°	0.95	230°	1.02
135°	0.96	240°	1.02
140°	0.97	250°	1.02
145°	0.97		
150°	0.98		
155°	0.98		
160°	0.99		
165°	0.99		
170°	0.99		

The following formula for determining the number of ribs is obtained using the idler correction factor c_4 :

$$z = \frac{P \cdot c_2}{P_N \cdot c_1 \cdot c_3 \cdot c_4}$$

RIBBED BELT PULLEYS

MEASURING PULLEYS – LENGTH MEASURING CONDITIONS TO DIN 7867 / ISO 9982

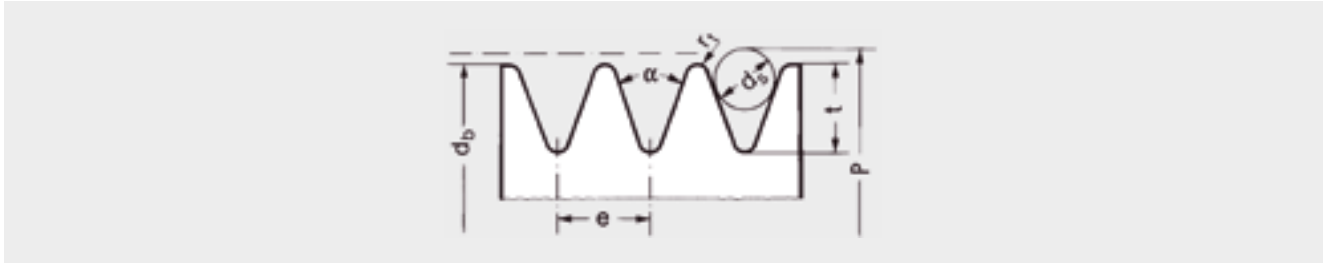

Table 15

Profile	Effective circumference $U_b = d_b \cdot \pi$ [mm]	Effective diameter d_b	Groove angle α $\pm 0.5^\circ$	Checking rod diameter d_s ± 0.01 [mm]	Diameter over rod P ± 0.1 [mm]	Groove depth t_{min} [mm]	$r_{t min}$ [mm]	Measuring force per rib Q [N]
PH*	100	31.8	40°	1.0	31.94	1.33	0.15	30
PH	300	95.5	40°	1.0	95.60	1.33	0.15	30
PJ*	100	31.8	40°	1.5	32.06	2.06	0.20	50
PJ	300	95.5	40°	1.5	95.72	2.06	0.20	50
PK	300	95.5	40°	2.5	96.48	3.45	0.25	100
PL	500	159.2	40°	3.5	161.51	4.92	0.40	200
PM	800	254.6	40°	7.0	259.17	10.03	0.75	450

*These values apply only for effective lengths under 457 mm.

The appropriate manufacturing tolerances for the grooves and dimensions of the measuring pulleys are given in tables 15 and 16. Care must be taken to monitor wear or damage. Other diameters may be used for the measuring pulleys providing the groove dimensions from the tables are used.

Measuring of Ribbed Belt Length

The belt is placed over two identical measuring pulleys with a groove configuration as shown in the adjoining figure. A load is applied to the moveable pulley until the measuring force Q is exerted on the ribbed belt. The ribbed belt should be rotated at least three revolutions before measuring the drive centre distance a . Only then is the belt settled properly into the pulley grooves and exact measurements are possible. The effective length is the result of twice the centre distance a plus the effective circumference of the measuring pulley.

$$L_b = 2 a + U_b$$

Method of Measuring Ribbed Belt Effective Length

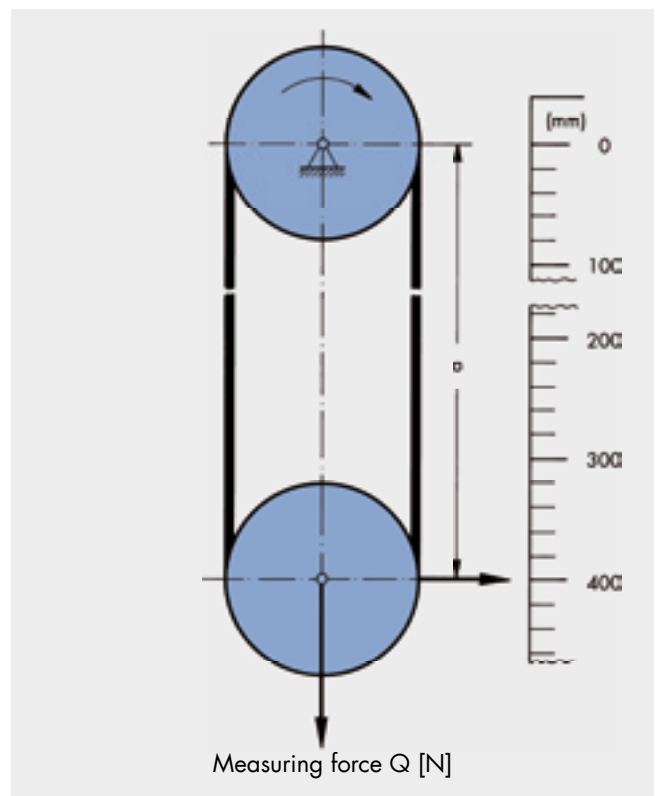

RIBBED BELT PULLEYS

DIMENSIONS TO DIN 7867 / ISO 9982

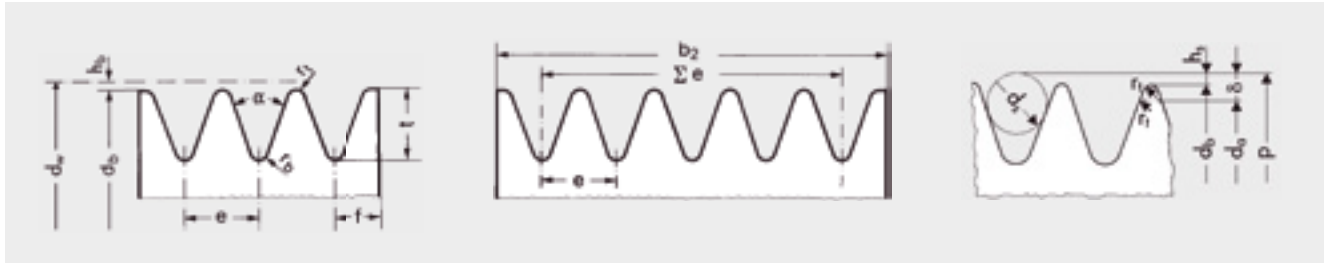

Table 16

Profile	Effective diameter d_b min [mm]	Groove angle α $\pm 0.5^\circ$	Groove pitch e [mm]	$\Sigma e \pm 0.3$ [mm]	Groove depth t_{min} [mm]	f_{min} [mm]	h_b [mm]	$r_{t min}$ [mm]	$r_{b max}$ [mm]	$2 h_s$ [mm]	$2 \delta_{max}$ [mm]
PH	13	40°	1.60 (± 0.03)	(z - 1) 1.60	1.33	1.3	0.80	0.15	0.30	0.11	0.69
PJ	20	40°	2.34 (± 0.03)	(z - 1) 2.34	2.06	1.8	1.25	0.20	0.40	0.23	0.81
PK	45	40°	3.56 (± 0.05)	(z - 1) 3.56	3.45	2.5	1.60	0.25	0.50	0.99	1.68
PL	75	40°	4.70 (± 0.05)	(z - 1) 4.70	4.92	3.3	3.50	0.40	0.40	2.36	3.50
PM	180	40°	9.40 (± 0.08)	(z - 1) 9.40	10.03	6.4	5.00	0.75	0.75	4.53	5.92

The diameter d_o may be reduced by the dimension $2 \delta - 2 h_s$ at the manufacturer's discretion.
The arc with radius r_1 must have an angle of at least 30° and merge tangentially with the edge of the groove.

Pulley Face Width b_2

$$b_2 = e (z - 1) + 2 f$$

The difference between the diameters, measured as distance p , between the outer tangential plane of the test pin in all the grooves of a pulley must not exceed the value given in table 17.

Table 17: Groove to Groove Diameter Variation

Pulley effective diameter [mm]	Tolerance for no. of grooves [mm]		Allowance for each extra groove [mm]
	≤ 6 grooves	≤ 10 grooves	
≤ 74	0.10	—	0.003
$> 74 \leq 500$	—	0.15	0.005
> 500	—	0.25	0.010

Material

All conventional easily machined material may be used, preferably steel, cast iron, aluminium alloy, brass or high strength plastics.

Surface Finish

Groove surface should have a maximum roughness $R_z \leq 3.2 \mu\text{m}$ and must be free from surface defects.

Balancing

For velocities $< 30 \text{ m/s}$ static balancing is sufficient. Dynamic balancing is necessary for velocities of $\geq 30 \text{ m/s}$.

Manufacture

Pulleys for optibelt RB ribbed belts are made to your specification. Cutting tools for ribbed belt pulleys are available on special request.

Table 18: Run Out Tolerance

Effective diameter d_b [mm]	Run out tolerance t_R
≤ 74	0.13
$> 74 \leq 250$	0.25
> 250	$0.25 + 0.0004$ per mm effective diameter above 250

Side Wobble Tolerance

The side wobble tolerance t_p is 0.002 mm for each mm effective diameter.

Pitch Diameter

The schematic illustration shows the seating of a ribbed belt in the pulley.

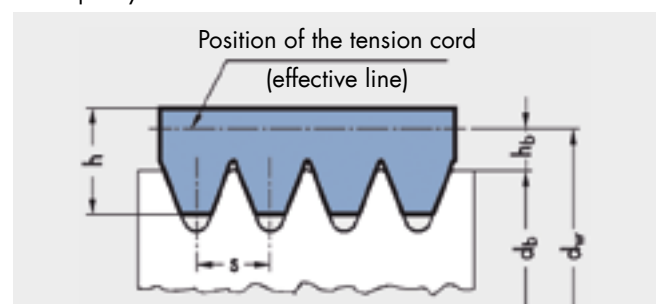

RIBBED BELT PULLEYS

STANDARD RANGE optibelt TB TAPER BUSHES



Taper bushes with metric bores and keyways to DIN 6885 part 1																
	Taper Bush										Material: EN-GJL-200 – DIN EN 1561					
	1008	1108	1210	1215	1310	1610	1615	2012	2517	3020	3030	3525	3535	4040	4545	5050
Bore diameter d ₂ [mm]	10	10	11	11	14	14	14	14	16	25	35	35	35	40	55	70
	11	11	12	12	16	16	16	16	18	28	38	38	38	42	60	75
	12	12	14	14	18	18	18	18	19	30	40	40	40	45	65	80
	14	14	16	16	19	19	19	19	20	32	42	42	42	48	70	85
	15	15	18	18	20	20	20	20	22	35	45	45	45	50	75	90
	16	16	19	19	22	22	22	22	24	38	48	48	48	55	80	95
	18	18	20	20	24	24	24	24	25	40	50	50	50	60	85	100
	19	19	22	22	25	25	25	25	28	42	55	55	55	65	90	105
	20	20	24	24	28	28	28	28	30	45	60	60	60	70	95	110
	22	22	25	25	30	30	30	30	32	48	65	65	65	75	100	115
	24▲	24	28	28	32	32	32	32	35	50	70	70	70	80	105	120
	25▲	25	30	30	35	35	35	35	38	55	75	75	75	85	110	125
		28▲	32	32		38	38	38	40	60		80	80	90		
					40	40	40	40	42	65		85	85	95		
					42▲	42▲	42	42	45	70		90	90	100		
								45	48	75						
								48	50							
								50	55							
								60	60							
Hexagon socket screws [inch]	1/4 x 1/2	1/4 x 1/2	3/8 x 5/8	3/8 x 5/8	3/8 x 5/8	3/8 x 5/8	3/8 x 5/8	7/16 x 7/8	1/2 x 1	5/8 x 1 1/4	5/8 x 1 1/4	1/2 x 1 1/2	1/2 x 1 1/2	5/8 x 1 3/4	3/4 x 2	7/8 x 2 1/4
Torque [Nm]	5.7	5.7	20	20	20	20	20	31	49	92	92	115	115	172	195	275
Bush length [mm]	22.3	22.3	25.4	38.1	25.4	25.4	38.1	31.8	44.5	50.8	76.2	63.5	88.9	101.6	114.3	127.0
Weight with d _{2 min} [≈ kg]	0.12	0.16	0.28	0.39	0.32	0.41	0.60	0.75	1.06	2.50	3.75	3.90	5.13	7.68	12.70	15.17

Over 3525: Cap head screw with hexagon socket ▲ This bore has a flat keyway.

Flat Keyway for Taper Bushes

Bore diameter d ₂ [mm]	Keyway width b [mm]	Keyway depth t ₂ [mm]	Bore diameter d ₂ [mm]	Keyway width b [mm]	Keyway depth t ₂ [mm]
24	8	2.0	28	8	2.0
25	8	1.3	42	12	2.2

Taper bushes with inch bores and keyway to British Standard BS 46 part 1																
	Taper Bush										Material: EN-GJL-200 – DIN EN 1561					
	1008	1108	1210	1215	1310	1610	1615	2012	2517	3020	3030	3525	3535	4040	4545	5050
Bore diameter d ₂ [inch]	3/8*	3/8*	1/2	5/8*	1/2*	1/2	1/2	5/8*	3/4	1 1/4	1 1/4	1 1/2	1 1/2	1 3/4*	2 1/4*	3*
	1/2	1/2	5/8	3/4	5/8*	5/8	5/8	3/4	7/8	1 3/8	1 3/8	1 5/8	1 5/8	1 7/8*	2 3/8*	3 1/4*
	5/8	5/8	3/4	7/8	3/4*	3/4	3/4	7/8	1	1 1/2	1 1/2	1 3/4	1 3/4	2*	2 1/2*	3 1/2*
	3/4	3/4	7/8	1	7/8*	7/8	7/8*	1	1 1/8	1 5/8	1 5/8	1 7/8	1 7/8	2 1/8*	2 3/4*	3 3/4*
	7/8	7/8	1	1 1/8	1*	1	1	1 1/8	1 1/4	1 3/4*	1 3/4*	2	2	2 1/4*	2 7/8*	4*
	1▲	1	1 1/8	1 1/4	1 1/8	1 1/8	1 1/8	1 1/4	1 3/8	1 7/8	1 7/8	2 1/8	2 1/8	2 3/8*	3*	4 1/4*
		1 1/8▲*	1 1/4		1 1/4	1 1/4	1 1/4	1 3/8	1 1/2	2	2	2 1/4	2 1/4	2 1/2*	3 1/4*	4 1/2*
				1 3/8	1 3/8	1 3/8	1 1/2	1 5/8	1 5/8	2 1/8*	2 1/8*	2 3/8	2 3/8	2 5/8*	3 3/8*	4 3/4*
					1 1/2	1 1/2	1 5/8	1 3/4	1 7/8	2 1/4	2 1/4	2 1/2	2 1/2	2 3/4*	3 1/2*	5▲*
					1 5/8	1 5/8▲*	1 3/4	1 7/8	2 3/8	2 3/8	2 3/8	2 5/8	2 5/8	2 7/8*	3 3/4*	
							1 7/8	2	2 1/2	2 1/2	2 3/4	2 3/4	2 3/4	3*	4*	
							2	2 1/8	2 5/8	2 5/8*	2 7/8	2 7/8	2 7/8	3 1/8*	4 1/4▲*	
								2 1/4	2 3/4	2 3/4*	3	3	3	3 1/4*	4 1/2▲*	
								2 3/8	2 7/8	2 7/8	3	3	3 1/8	3 1/8		
								2 1/2	3	3 1/4	3 1/4	3 1/4	3 1/4	3 1/2*		
												3 3/8	3 3/8	3 3/4▲*		
												3 1/2▲	3 1/2▲	4▲*		
Hexagon socket screws [inch]	1/4 x 1/2	1/4 x 1/2	3/8 x 5/8	3/8 x 5/8	3/8 x 5/8	3/8 x 5/8	3/8 x 5/8	7/16 x 7/8	1/2 x 1	5/8 x 1 1/4	5/8 x 1 1/4	1/2 x 1 1/2	1/2 x 1 1/2	5/8 x 1 3/4	3/4 x 2	7/8 x 2 1/4
Torque [Nm]	5.7	5.7	20	20	20	20	20	31	49	92	92	115	115	172	195	275
Bush length [mm]	22.3	22.3	25.4	38.1	25.4	25.4	38.1	31.8	44.5	50.8	76.2	63.5	88.9	101.6	114.3	127.0
Weight with d _{2 min} [≈ kg]	0.12	0.16	0.28	0.39	0.32	0.41	0.60	0.75	1.06	2.50	3.75	3.90	5.13	7.68	12.70	15.17

Over 3525: Cap head screw with hexagon socket * Non-standard items ▲ This bore has a flat keyway.

RIBBED BELT PULLEYS FOR TAPER BUSHES, PROFILE PJ

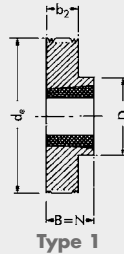

Designation	No. of grooves	Pulley type	Material	d_b [mm]	b_2 [mm]	B [mm]	N [mm]	D [mm]	Taper bush
TB 4 PJ 47.5	4	1	GG	47.5	13	23	23	47.5	1008
TB 4 PJ 52.5	4	1	GG	52.5	13	23	23	47.5	1008
TB 4 PJ 57.5	4	1	GG	57.5	13	23	23	54.0	1108
TB 4 PJ 62.5	4	1	GG	62.5	13	23	23	54.0	1108
TB 4 PJ 67.5	4	1	GG	67.5	13	23	23	54.0	1108
TB 4 PJ 72.5	4	1	GG	72.5	13	23	23	54.0	1108
TB 4 PJ 77.5	4	1	GG	77.5	13	26	26	70.0	1210
TB 4 PJ 82.5	4	1	GG	82.5	13	26	26	78.0	1210
TB 4 PJ 87.5	4	1	GG	87.5	13	26	26	78.0	1210
TB 4 PJ 92.5	4	1	GG	92.5	13	26	26	78.0	1210
TB 4 PJ 97.5	4	1	GG	97.5	13	26	26	78.0	1210
TB 4 PJ 102.5	4	1	GG	102.5	13	26	26	85.0	1610
TB 4 PJ 107.5	4	1	GG	107.5	13	26	26	85.0	1610
TB 4 PJ 112.5	4	1	GG	112.5	13	26	26	85.0	1610
TB 4 PJ 117.5	4	1	GG	117.5	13	26	26	85.0	1610
TB 4 PJ 122.5	4	1	GG	122.5	13	26	26	85.0	1610
TB 4 PJ 127.5	4	1	GG	127.5	13	26	26	85.0	1610
TB 4 PJ 137.5	4	1	GG	137.5	13	26	26	85.0	1610
TB 4 PJ 152.5	4	1	GG	152.5	13	26	26	85.0	1610
TB 4 PJ 162.5	4	1	GG	162.5	13	26	26	85.0	1610
TB 4 PJ 172.5	4	1	GG	172.5	13	26	26	85.0	1610
TB 4 PJ 182.5	4	1	GG	182.5	13	26	26	85.0	1610
TB 4 PJ 192.5	4	1	GG	192.5	13	26	26	85.0	1610
TB 4 PJ 202.5	4	1	GG	202.5	13	33	33	100.0	2012
TB 4 PJ 222.5	4	1	GG	222.5	13	33	33	100.0	2012

Taper bush	1008	1108	1210	1610	2012
Bore d_2 [mm] from ... to ...	10-25	10-28	11-32	14-42	14-50

GG= Cast iron
Further sizes upon request.
We reserve to alter specifications without notice.
Bore diameters d_2 see page 37.

RIBBED BELT PULLEYS FOR TAPER BUSHES, PROFILE PJ

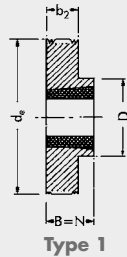

Type 1

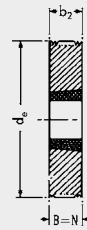

Type 4

Designation	No. of grooves	Pulley type	Material	d_b [mm]	b_2 [mm]	B [mm]	N [mm]	D [mm]	Taper bush
TB 8 PJ 47.5	8	4	GG	47.5	23	23	23	—	1008
TB 8 PJ 52.5	8	4	GG	52.5	23	23	23	—	1008
TB 8 PJ 57.5	8	4	GG	57.5	23	23	23	—	1108
TB 8 PJ 62.5	8	4	GG	62.5	23	23	23	—	1108
TB 8 PJ 67.5	8	4	GG	67.5	23	23	23	—	1108
TB 8 PJ 72.5	8	4	GG	72.5	23	23	23	—	1108
TB 8 PJ 77.5	8	1	GG	77.5	23	26	26	70.0	1210
TB 8 PJ 82.5	8	1	GG	82.5	23	26	26	78.0	1210
TB 8 PJ 87.5	8	1	GG	87.5	23	26	26	78.0	1210
TB 8 PJ 92.5	8	1	GG	92.5	23	26	26	78.0	1210
TB 8 PJ 97.5	8	1	GG	97.5	23	26	26	78.0	1210
TB 8 PJ 102.5	8	1	GG	102.5	23	26	26	85.0	1610
TB 8 PJ 107.5	8	1	GG	107.5	23	26	26	85.0	1610
TB 8 PJ 112.5	8	1	GG	112.5	23	26	26	85.0	1610
TB 8 PJ 117.5	8	1	GG	117.5	23	26	26	85.0	1610
TB 8 PJ 122.5	8	1	GG	122.5	23	26	26	85.0	1610
TB 8 PJ 127.5	8	1	GG	127.5	23	26	26	85.0	1610
TB 8 PJ 137.5	8	1	GG	137.5	23	26	26	85.0	1610
TB 8 PJ 152.5	8	1	GG	152.5	23	26	26	85.0	1610
TB 8 PJ 162.5	8	1	GG	162.5	23	26	26	85.0	1610
TB 8 PJ 172.5	8	1	GG	172.5	23	26	26	85.0	1610
TB 8 PJ 182.5	8	1	GG	182.5	23	26	26	85.0	1610
TB 8 PJ 192.5	8	1	GG	192.5	23	26	26	85.0	1610
TB 8 PJ 202.5	8	1	GG	202.5	23	33	33	100.0	2012
TB 8 PJ 222.5	8	1	GG	222.5	23	33	33	100.0	2012

Taper bush	1008	1108	1210	1610	2012
Bore d_2 [mm] from ... to ...	10-25	10-28	11-32	14-42	14-50

GG = Cast iron
Further sizes upon request.
We reserve to alter specifications without notice.
Bore diameters d_2 see page 37.

RIBBED BELT PULLEYS FOR TAPER BUSHES, PROFILE PJ

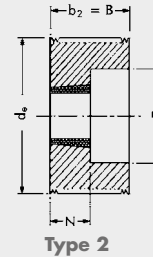
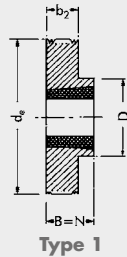

Designation	No. of grooves	Pulley type	Material	d_b [mm]	b_2 [mm]	B [mm]	N [mm]	D [mm]	Taper bush
TB 12 PJ 62.5	12	2	GG	62.5	32	32	23	50.0	1108
TB 12 PJ 67.5	12	2	GG	67.5	32	32	23	50.0	1108
TB 12 PJ 72.5	12	2	GG	72.5	32	32	23	50.0	1108
TB 12 PJ 77.5	12	2	GG	77.5	32	32	26	62.0	1210
TB 12 PJ 82.5	12	2	GG	82.5	32	32	26	62.0	1210
TB 12 PJ 87.5	12	2	GG	87.5	32	32	26	70.0	1610
TB 12 PJ 92.5	12	2	GG	92.5	32	32	26	70.0	1610
TB 12 PJ 97.5	12	2	GG	97.5	32	32	26	70.0	1610
TB 12 PJ 102.5	12	2	GG	102.5	32	32	26	70.0	1610
TB 12 PJ 107.5	12	2	GG	107.5	32	32	26	70.0	1610
TB 12 PJ 112.5	12	2	GG	112.5	32	32	26	70.0	1610
TB 12 PJ 117.5	12	2	GG	117.5	32	32	26	70.0	1610
TB 12 PJ 122.5	12	2	GG	122.5	32	32	26	70.0	1610
TB 12 PJ 127.5	12	1	GG	127.5	32	32	33	100.0	2012
TB 12 PJ 137.5	12	1	GG	137.5	32	32	33	100.0	2012
TB 12 PJ 152.5	12	1	GG	152.5	32	32	33	100.0	2012
TB 12 PJ 162.5	12	1	GG	162.5	32	32	33	100.0	2012
TB 12 PJ 172.5	12	1	GG	172.5	32	32	33	100.0	2012
TB 12 PJ 182.5	12	1	GG	182.5	32	46	46	110.0	2517
TB 12 PJ 192.5	12	1	GG	192.5	32	46	46	110.0	2517
TB 12 PJ 202.5	12	1	GG	202.5	32	46	46	110.0	2517
TB 12 PJ 222.5	12	1	GG	222.5	32	46	46	110.0	2517

Taper bush	1108	1210	1610	2012	2517
Bore d_2 [mm] from ... to ...	10-28	11-32	14-42	14-50	16-60

GG = Cast iron
Further sizes upon request.
We reserve to alter specifications without notice.
Bore diameters d_2 see page 37.

RIBBED BELT PULLEYS FOR TAPER BUSHES, PROFILE PJ

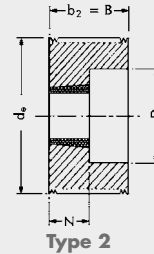
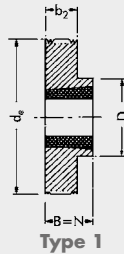

Designation	No. of grooves	Pulley type	Material	d_b [mm]	b_2 [mm]	B [mm]	N [mm]	D [mm]	Taper bush
TB 16 PJ 62.5	16	2	GG	62.5	41	41	23	50.0	1108
TB 16 PJ 67.5	16	2	GG	67.5	41	41	23	50.0	1108
TB 16 PJ 72.5	16	2	GG	72.5	41	41	26	62.0	1210
TB 16 PJ 77.5	16	2	GG	77.5	41	41	26	62.0	1210
TB 16 PJ 82.5	16	2	GG	82.5	41	41	26	62.0	1210
TB 16 PJ 87.5	16	2	GG	87.5	41	41	26	70.0	1610
TB 16 PJ 92.5	16	2	GG	92.5	41	41	26	70.0	1610
TB 16 PJ 97.5	16	2	GG	97.5	41	41	26	70.0	1610
TB 16 PJ 102.5	16	2	GG	102.5	41	41	26	70.0	1610
TB 16 PJ 107.5	16	2	GG	107.5	41	41	26	70.0	1610
TB 16 PJ 112.5	16	2	GG	112.5	41	41	33	85.0	2012
TB 16 PJ 117.5	16	2	GG	117.5	41	41	33	85.0	2012
TB 16 PJ 122.5	16	2	GG	122.5	41	41	33	85.0	2012
TB 16 PJ 127.5	16	2	GG	127.5	41	41	33	85.0	2012
TB 16 PJ 137.5	16	2	GG	137.5	41	41	33	85.0	2012
TB 16 PJ 152.5	16	2	GG	152.5	41	41	33	85.0	2012
TB 16 PJ 162.5	16	2	GG	162.5	41	41	33	85.0	2012
TB 16 PJ 172.5	16	2	GG	172.5	41	41	33	85.0	2012
TB 16 PJ 182.5	16	1	GG	182.5	41	46	46	110.0	2517
TB 16 PJ 192.5	16	1	GG	192.5	41	46	46	110.0	2517
TB 16 PJ 202.5	16	1	GG	202.5	41	46	46	110.0	2517
TB 16 PJ 222.5	16	1	GG	222.5	41	46	46	110.0	2517

Taper bush	1108	1210	1610	2012	2517
Bore d_2 [mm] from ... to ...	10-28	11-32	14-42	14-50	16-60

GG = Cast iron
Further sizes upon request.
We reserve to alter specifications without notice.
Bore diameters d_2 see page 37.

RIBBED BELT PULLEYS FOR TAPER BUSHES, PROFILE PL

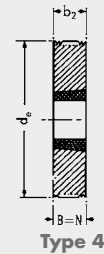
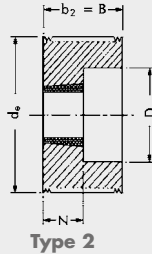
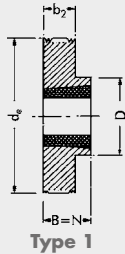

Designation	No. of grooves	Pulley type	Material	d _b [mm]	b ₂ [mm]	B [mm]	N [mm]	D [mm]	Taper bush
TB 6 PL 78	6	2	GG	78	33	33	26	62.0	1210
TB 6 PL 83	6	2	GG	83	33	33	26	62.0	1210
TB 6 PL 88	6	2	GG	88	33	33	26	70.0	1610
TB 6 PL 93	6	2	GG	93	33	33	26	70.0	1610
TB 6 PL 98	6	2	GG	98	33	33	26	70.0	1610
TB 6 PL 103	6	2	GG	103	33	33	26	70.0	1610
TB 6 PL 108	6	2	GG	108	33	33	26	70.0	1610
TB 6 PL 113	6	2	GG	113	33	33	26	70.0	1610
TB 6 PL 118	6	2	GG	118	33	33	26	70.0	1610
TB 6 PL 123	6	4	GG	123	33	33	33	—	2012
TB 6 PL 133	6	4	GG	133	33	33	33	—	2012
TB 6 PL 148	6	4	GG	148	33	33	33	—	2012
TB 6 PL 158	6	4	GG	158	33	33	33	—	2012
TB 6 PL 168	6	4	GG	168	33	33	33	—	2012
TB 6 PL 178	6	1	GG	178	33	46	46	110.0	2517
TB 6 PL 188	6	1	GG	188	33	46	46	110.0	2517
TB 6 PL 198	6	1	GG	198	33	46	46	110.0	2517
TB 6 PL 218	6	1	GG	218	33	46	46	110.0	2517
TB 6 PL 238	6	1	GG	238	33	46	46	110.0	2517
TB 6 PL 258	6	1	GG	258	33	46	46	110.0	2517
TB 6 PL 278	6	1	GG	278	33	46	46	110.0	2517
TB 6 PL 298	6	1	GG	298	33	46	46	110.0	2517
TB 6 PL 318	6	1	GG	318	33	46	46	110.0	2517
TB 6 PL 348	6	1	GG	348	33	46	46	110.0	2517
TB 6 PL 388	6	1	GG	388	33	46	46	110.0	2517

Taper bush	1210	1610	2012	2517
Bore d ₂ [mm] from ... to ...	11-32	14-42	14-50	16-60

GG = Cast iron
Further sizes upon request.
We reserve to alter specifications without notice.
Bore diameters d₂ see page 37.

RIBBED BELT PULLEYS FOR TAPER BUSHES, PROFILE PL

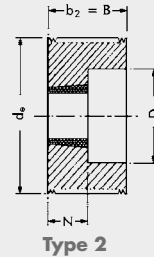
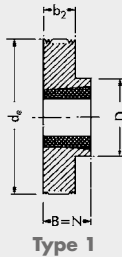

Designation	No. of grooves	Pulley type	Material	d_b [mm]	b_2 [mm]	B [mm]	N [mm]	D [mm]	Taper bush
TB 8 PL 78	8	2	GG	78	42	42	26	62.0	1210
TB 8 PL 83	8	2	GG	83	42	42	26	62.0	1210
TB 8 PL 88	8	2	GG	88	42	42	26	70.0	1610
TB 8 PL 93	8	2	GG	93	42	42	26	70.0	1610
TB 8 PL 98	8	2	GG	98	42	42	26	70.0	1610
TB 8 PL 103	8	2	GG	103	42	42	33	85.0	2012
TB 8 PL 108	8	2	GG	108	42	42	33	85.0	2012
TB 8 PL 113	8	2	GG	113	42	42	33	85.0	2012
TB 8 PL 118	8	2	GG	118	42	42	33	85.0	2012
TB 8 PL 123	8	2	GG	123	42	42	33	85.0	2012
TB 8 PL 133	8	2	GG	133	42	42	33	85.0	2012
TB 8 PL 148	8	2	GG	148	42	42	33	85.0	2012
TB 8 PL 158	8	2	GG	158	42	42	33	85.0	2012
TB 8 PL 168	8	2	GG	168	42	42	33	85.0	2012
TB 8 PL 178	8	1	GG	178	42	46	46	110.0	2517
TB 8 PL 188	8	1	GG	188	42	46	46	110.0	2517
TB 8 PL 198	8	1	GG	198	42	46	46	110.0	2517
TB 8 PL 218	8	1	GG	218	42	46	46	110.0	2517
TB 8 PL 238	8	1	GG	238	42	46	46	110.0	2517
TB 8 PL 258	8	1	GG	258	42	46	46	110.0	2517
TB 8 PL 278	8	1	GG	278	42	46	46	110.0	2517
TB 8 PL 298	8	1	GG	298	42	46	46	110.0	2517
TB 8 PL 318	8	1	GG	318	42	46	46	110.0	2517
TB 8 PL 348	8	1	GG	348	42	46	46	110.0	2517
TB 8 PL 388	8	1	GG	388	42	46	46	110.0	2517

Taper bush	1210	1610	2012	2517
Bore d_2 [mm] from ... to ...	11-32	14-42	14-50	16-60

GG = Cast iron
Further sizes upon request.
We reserve to alter specifications without notice.
Bore diameters d_2 see page 37.

RIBBED BELT PULLEYS FOR TAPER BUSHES, PROFILE PL

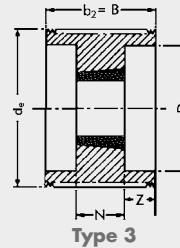
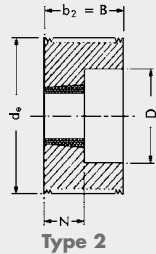

Designation	No. of grooves	Pulley type	Material	d _b [mm]	b ₂ [mm]	B [mm]	N [mm]	D [mm]	Taper bush
TB 10 PL 88	10	3	GG	88	53	53	26	70.0	1610
TB 10 PL 93	10	3	GG	93	53	53	26	70.0	1610
TB 10 PL 98	10	3	GG	98	53	53	26	70.0	1610
TB 10 PL 103	10	2	GG	103	53	53	33	85.0	2012
TB 10 PL 108	10	2	GG	108	53	53	33	85.0	2012
TB 10 PL 113	10	2	GG	113	53	53	33	85.0	2012
TB 10 PL 118	10	2	GG	118	53	53	33	85.0	2012
TB 10 PL 123	10	2	GG	123	53	53	33	85.0	2012
TB 10 PL 133	10	2	GG	133	53	53	33	85.0	2012
TB 10 PL 148	10	2	GG	148	53	53	33	85.0	2012
TB 10 PL 158	10	2	GG	158	53	53	33	85.0	2012
TB 10 PL 168	10	2	GG	168	53	53	33	85.0	2012
TB 10 PL 178	10	2	GG	178	53	53	46	105.0	2517
TB 10 PL 188	10	2	GG	188	53	53	46	105.0	2517
TB 10 PL 198	10	2	GG	198	53	53	46	105.0	2517
TB 10 PL 218	10	2	GG	218	53	53	46	105.0	2517
TB 10 PL 238	10	2	GG	238	53	53	46	105.0	2517
TB 10 PL 258	10	2	GG	258	53	53	46	105.0	2517
TB 10 PL 278	10	2	GG	278	53	53	46	105.0	2517
TB 10 PL 298	10	2	GG	298	53	53	46	105.0	2517
TB 10 PL 318	10	2	GG	318	53	53	46	105.0	2517
TB 10 PL 348	10	2	GG	348	53	53	46	105.0	2517
TB 10 PL 388	10	2	GG	388	53	53	46	105.0	2517

Taper bush	1610	2012	2517
Bore d ₂ [mm] from ... to ...	14-42	14-50	16-60

GG = Cast iron
Further sizes upon request.
We reserve to alter specifications without notice.
Bore diameters d₂ see page 37.

RIBBED BELT PULLEYS FOR TAPER BUSHES, PROFILE PL

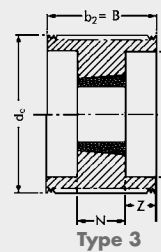
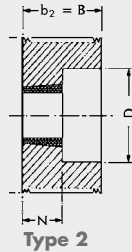

Designation	No. of grooves	Pulley type	Material	d_b [mm]	b_2 [mm]	B [mm]	N [mm]	D [mm]	Taper bush
TB 12 PL 88	12	3	GG	88	62	62	26	70.0	1610
TB 12 PL 93	12	3	GG	93	62	62	26	70.0	1610
TB 12 PL 98	12	3	GG	98	62	62	26	70.0	1610
TB 12 PL 103	12	3	GG	103	62	62	33	85.0	2012
TB 12 PL 108	12	3	GG	108	62	62	33	85.0	2012
TB 12 PL 113	12	3	GG	113	62	62	33	85.0	2012
TB 12 PL 118	12	3	GG	118	62	62	33	85.0	2012
TB 12 PL 123	12	3	GG	123	62	62	33	85.0	2012
TB 12 PL 133	12	3	GG	133	62	62	33	85.0	2012
TB 12 PL 148	12	2	GG	148	62	62	46	105.0	2517
TB 12 PL 158	12	2	GG	158	62	62	46	105.0	2517
TB 12 PL 168	12	2	GG	168	62	62	46	105.0	2517
TB 12 PL 178	12	2	GG	178	62	62	46	105.0	2517
TB 12 PL 188	12	2	GG	188	62	62	46	105.0	2517
TB 12 PL 198	12	2	GG	198	62	62	46	105.0	2517
TB 12 PL 218	12	2	GG	218	62	62	46	105.0	2517
TB 12 PL 238	12	2	GG	238	62	62	52	130.0	3020
TB 12 PL 258	12	2	GG	258	62	62	52	130.0	3020
TB 12 PL 278	12	2	GG	278	62	62	52	130.0	3020
TB 12 PL 298	12	2	GG	298	62	62	52	130.0	3020
TB 12 PL 318	12	2	GG	318	62	62	52	130.0	3020
TB 12 PL 348	12	2	GG	348	62	62	52	130.0	3020
TB 12 PL 388	12	2	GG	388	62	62	52	130.0	3020

Taper bush	1610	2012	2557	3020
Bore d_2 [mm] from ... to ...	14-42	14-50	16-60	25-75

GG = Cast iron
Further sizes upon request.
We reserve to alter specifications without notice.
Bore diameter d_2 see page 37.

RIBBED BELT PULLEYS FOR TAPER BUSHES, PROFILE PL

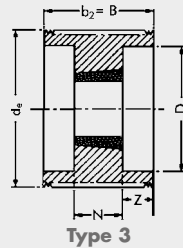

Designation	No. of grooves	Pulley type	Material	d_b [mm]	b_2 [mm]	B [mm]	N [mm]	D [mm]	Taper bush
TB 16 PL 103	16	3	GG	103	80	80	33	85.0	2012
TB 16 PL 108	16	3	GG	108	80	80	33	85.0	2012
TB 16 PL 113	16	3	GG	113	80	80	33	85.0	2012
TB 16 PL 118	16	3	GG	118	80	80	33	85.0	2012
TB 16 PL 123	16	3	GG	123	80	80	33	85.0	2012
TB 16 PL 133	16	3	GG	133	80	80	33	85.0	2012
TB 16 PL 148	16	3	GG	148	80	80	46	105.0	2517
TB 16 PL 158	16	3	GG	158	80	80	46	105.0	2517
TB 16 PL 168	16	3	GG	168	80	80	46	105.0	2517
TB 16 PL 178	16	3	GG	178	80	80	46	105.0	2517
TB 16 PL 188	16	3	GG	188	80	80	46	105.0	2517
TB 16 PL 198	16	3	GG	198	80	80	46	105.0	2517
TB 16 PL 218	16	3	GG	218	80	80	46	105.0	2517
TB 16 PL 238	16	3	GG	238	80	80	52	130.0	3020
TB 16 PL 258	16	3	GG	258	80	80	52	130.0	3020
TB 16 PL 278	16	3	GG	278	80	80	52	130.0	3020
TB 16 PL 298	16	3	GG	298	80	80	52	130.0	3020
TB 16 PL 318	16	3	GG	318	80	80	52	130.0	3020
TB 16 PL 348	16	3	GG	348	80	80	52	130.0	3020
TB 16 PL 388	16	3	GG	388	80	80	52	130.0	3020

Taper bush	2012	2557	3020
Bore d_2 [mm] from ... to ...	14-50	16-60	25-75

GG = Cast iron
Further sizes upon request.
We reserve to alter specifications without notice.
Bore diameters d_2 see page 37.

RIBBED BELT PULLEYS

FOR CYLINDRICAL BORE, PROFILE PJ

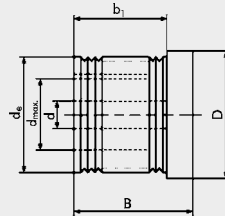

Type VB (for cylindrical bore)

Designation	No. of grooves	Pulley type	Material	d_b [mm]	b_1 [mm]	B [mm]	D [mm]	Pilot bore d [mm]	Finished bore d_{max} [mm]	Weight [≈ kg]
4 PJ 22.5	4	VB	GG	22.5	13	20	25	8	12.0	0.045
4 PJ 27.5	4	VB	GG	27.5	13	20	30	8	14.0	0.070
4 PJ 32.5	4	VB	GG	32.5	13	20	35	8	18.0	0.100
4 PJ 37.5	4	VB	GG	37.5	13	20	40	8	20.0	0.135
4 PJ 42.5	4	VB	GG	42.5	13	20	45	8	22.0	0.180
8 PJ 22.5	8	VB	GG	22.5	23	30	25	8	12.0	0.063
8 PJ 27.5	8	VB	GG	27.5	23	30	30	8	14.0	0.100
8 PJ 32.5	8	VB	GG	32.5	23	30	35	8	18.0	0.150
8 PJ 37.5	8	VB	GG	37.5	23	30	40	8	20.0	0.200
8 PJ 42.5	8	VB	GG	42.5	23	30	45	8	22.0	0.265
12 PJ 22.5	12	VB	GG	22.5	32	40	25	8	12.0	0.086
12 PJ 27.5	12	VB	GG	27.5	32	40	30	8	14.0	0.140
12 PJ 32.5	12	VB	GG	32.5	32	40	35	8	18.0	0.200
12 PJ 37.5	12	VB	GG	37.5	32	40	40	8	20.0	0.280
12 PJ 42.5	12	VB	GG	42.5	32	40	45	8	22.0	0.360

GG = Cast iron

Further sizes upon request.

We reserve to alter specifications without notice.

DESIGN HINTS

RIBBED BELT TENSION



The correct level of belt tension is of great importance for trouble free transmission of power, and for the achievement of an acceptable belt service life. Often, tension which is either too high or too low results in early belt failure. A belt which is over tensioned sometimes causes bearing failure in the driver or driven unit.

It has been shown that the more common tensioning instructions – e. g. using the “thumb pressure deflection method” – do not result in tension being obtained which would enable drives to be operated at optimum efficiency. It is therefore recommended that the required static belt tension “T” be calculated individually for every drive using the following Optibelt formulae. The best initial tension is the absolute minimum for a drive which permits the highest level of power transmission under consideration of the normal slip.

Once the ribbed belt has been fitted and the calculated shaft load applied, the tension should be checked, using our Optibelt tension gauge.

The belt should be observed regularly during the first few hours of service. Experience indicates that the first retensioning should be undertaken after running at full load for 0.5 to 4 hours to take up the initial belt stretch.

After approximately 24 hours’ running, especially if the belt has not run continuously under full load conditions, the drive should be checked and, if necessary, retensioned. After this, maintenance intervals for the drive can then be increased considerably. In addition, our installation and maintenance instructions should be observed.

Over- or undertensioning of the drive will be avoided if the belt tension is calculated, set and checked by one of the following methods:

I. Checking the Belt Tension by Span Deflection

This method provides an indirect measurement of the calculated or actual static belt tension.

- E = Belt deflection per 100 mm span length [mm]
- E_a = Belt deflection for a given span length [mm]
- f = Load used to set belt tension per rib [N]

- k = Constant for calculation of centrifugal force
- L = Span length [mm]
- S₀ = Minimum static shaft loading [N]
- T = Minimum static belt tension per rib [N]

1. Calculate the static belt tension using the following formula:

$$T \approx \frac{500 \cdot (2.03 - c_1) \cdot P_B}{c_1 \cdot z \cdot v} + k \cdot v^2$$

The drive should initially be tensioned to a maximum of 1.3 T (initial tensioning).

2. Determine E – the deflection per 100 mm length – from the belt tension characteristics as given in diagram 2, page 49.
3. Calculate E_a – the deflection for a given span length – for the actual drive span length L:

$$E_a \approx \frac{E \cdot L}{100}$$

$$L = \alpha_{nom} \cdot \sin \frac{\beta}{2}$$

Apply load f* using the value from Diagram 2 at right angles to the span at its centre point, as shown in the figure below. Measure the deflection and adjust if necessary until the correct belt tension is achieved.

* When choosing the load to set belt tension f, the number of ribs must be taken into consideration.

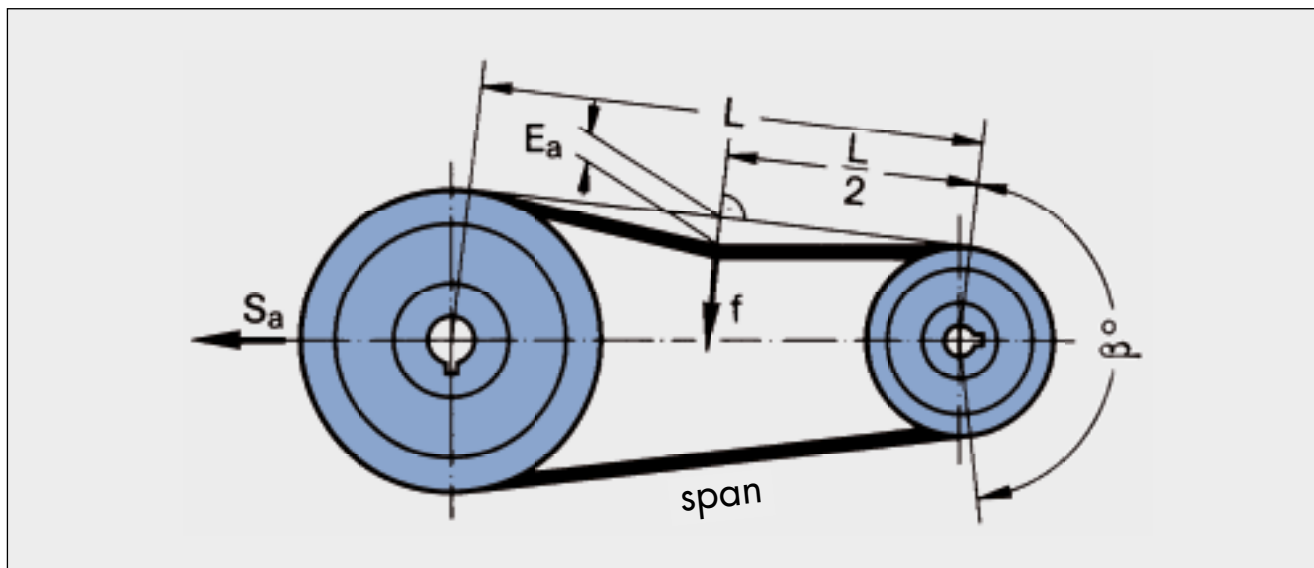

DESIGN HINTS

RIBBED BELT TENSION



Diagram 2: Ribbed Belt Tension Graphs

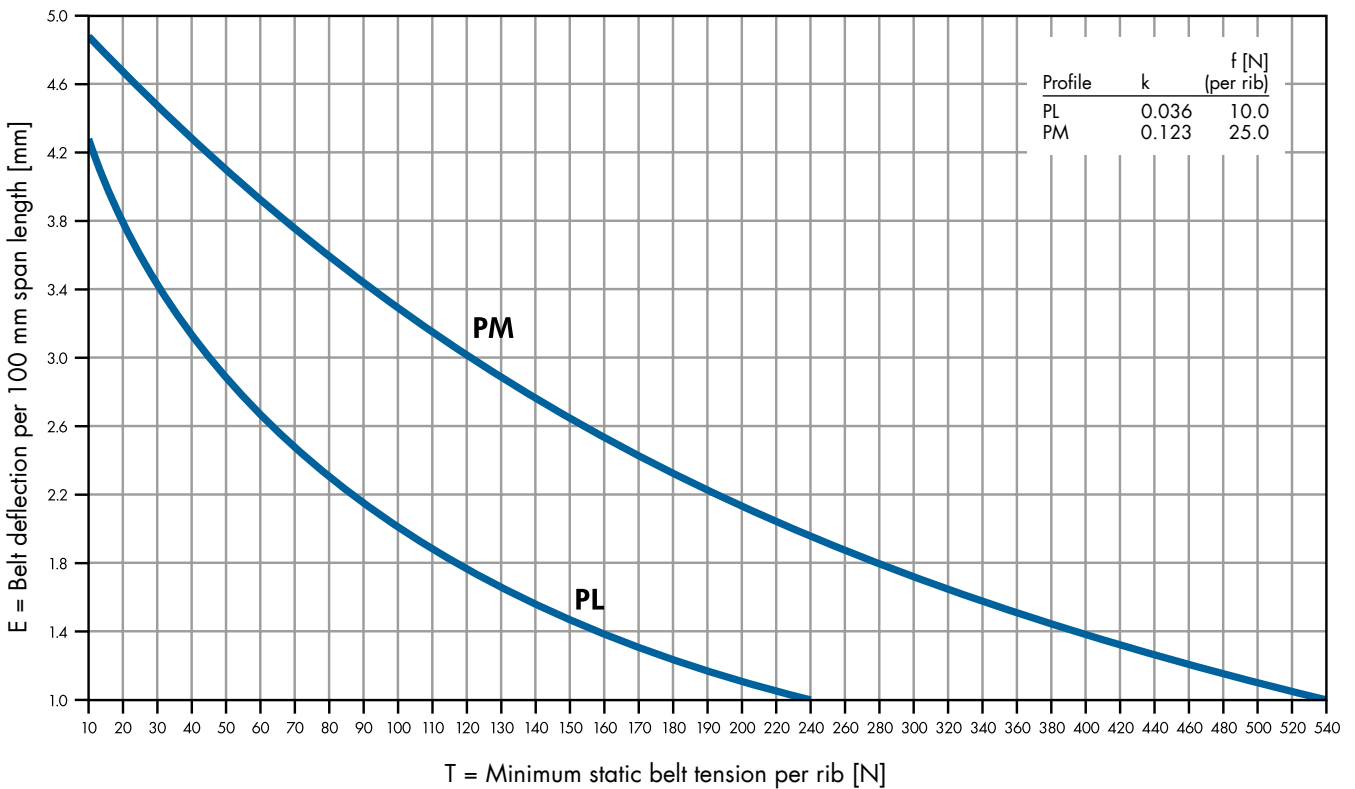
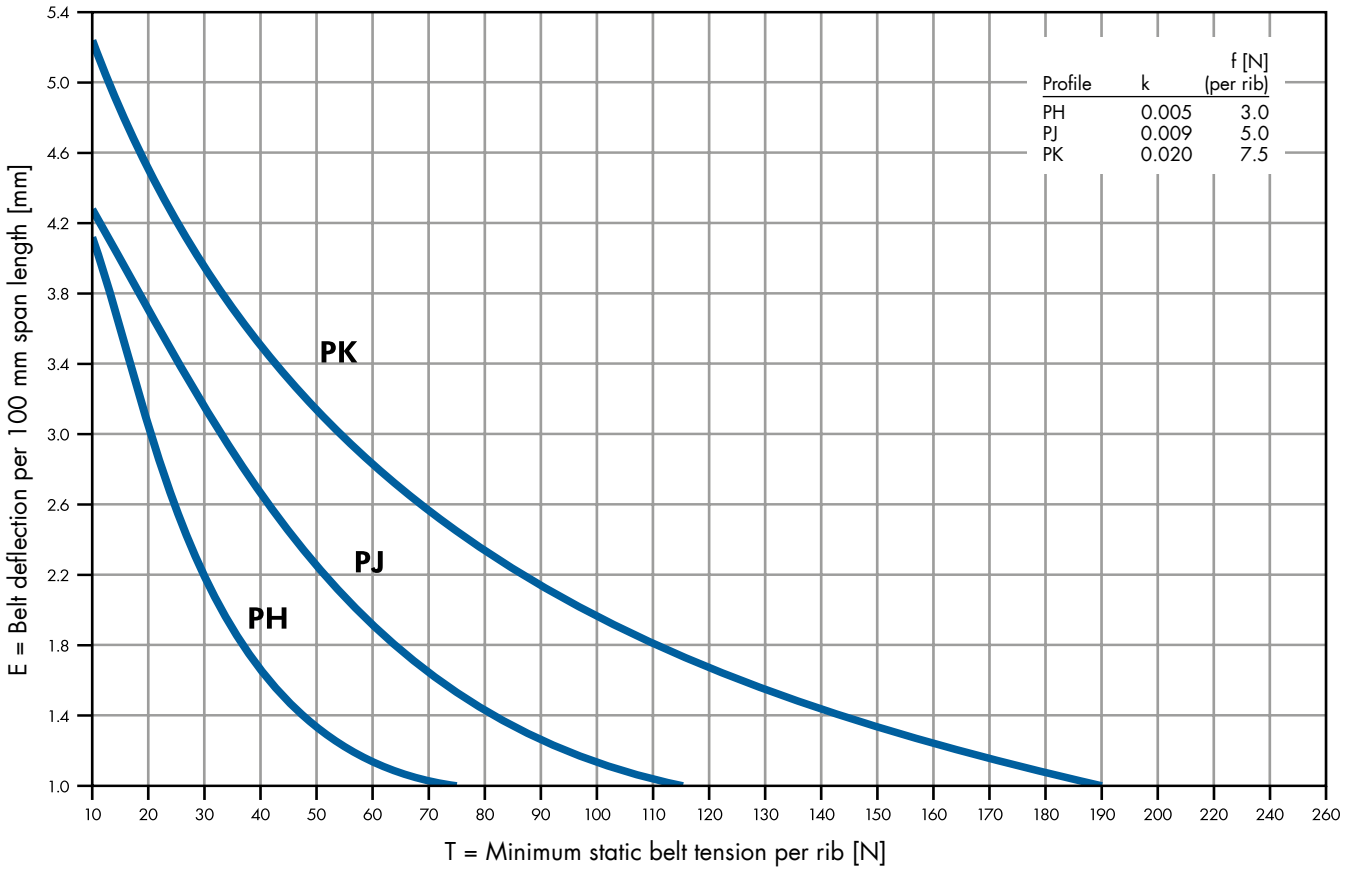

DESIGN HINTS

RIBBED BELT TENSION



II. Checking the Ribbed Belt Tension with a "Length Addition Value"

It has become evident that span deflection methods are not always the ideal checking procedures for ribbed belts. The following very easy method for determining the belt tension is therefore recommended:

1. Calculate the static belt tension "T".

$$T \approx \frac{500 \cdot (2.03 - c_1) \cdot P_B}{c_1 \cdot z \cdot v} + k \cdot v^2$$

2. The outside length L_a of the ribbed belt should be measured on the top surface with the belt slack prior to fitting it to the drive. Measurement may also be carried out on the drive itself, but **without tension**.

3. Calculate the length addition value "A" by using the formula:

$$A \approx L_{BSf} \cdot R$$

R = Stretch factor from table 19, page 51

4. This length addition value "A" should then be added to the measured outside length (from step 2).

$$L_a^* \approx L_a + A$$

5. The ribbed belt should then be tensioned until the outside length L_a^* calculated in step 4 is obtained. The belt tension will then be correct.
6. If the drive is to be retensioned, the ribbed belt must first be slackened off so that it can be measured in a stress free condition. The procedure as detailed in steps 4 and 5 is then repeated.

Tighten the belt until the length measured around the outside is 1103 mm. The belt is then correctly tensioned.

Example:

$$P_B = 23.4 \text{ kW}$$

$$c_1 = 1.0$$

$$v = 16.6 \text{ m/s}$$

Drive specification with 1 optibelt RB ribbed belt
12 PL 1075

$$T \approx \frac{500 \cdot (2.03 - 1.0) \cdot 23.4}{1.0 \cdot 12 \cdot 16.6} + 0.036 \cdot 16.6^2 \approx 70 \text{ N}$$

When fitted for the first time, the tension should be multiplied by a factor of 1.3.

$$T \approx 1.3 \cdot 70 \approx 91 \text{ N}$$

Length measured on the back of the belt whilst slack
 $L_a = 1100 \text{ mm}$

$$A \approx 1075 \cdot 0.00264 \approx 3 \text{ mm}$$

$$L_a^* \approx 1100 + 3 = 1103 \text{ mm}$$

III. Checking the Ribbed Belt Tension by Measurement of the Static Shaft Loading

A very accurate method for the setting of the correct belt tension is by direct measurement of the static shaft loading using the formula:

$$S_a \approx 2 T \cdot \sin \frac{\beta}{2} \cdot z$$

This checking method does, however, call for specialised measuring instruments.

DESIGN HINTS

RIBBED BELT TENSION



Table 19: Stretch Factor R for optibelt RB Ribbed Belts

Profile	PH	PJ	PK	PL	PM
15	0.00155	0.00090			
20	0.00207	0.00130			
25	0.00263	0.00168			
30	0.00331	0.00206	0.00065	0.00066	
35	0.00407	0.00248	0.00077	0.00080	
40	0.00500	0.00300	0.00093	0.00094	
45	0.00600	0.00348	0.00114	0.00109	
50	0.00700	0.00406	0.00136	0.00127	
55	0.00831	0.00459	0.00160	0.00142	0.00062
60	0.00958	0.00522	0.00192	0.00160	0.00072
65	0.01085	0.00580	0.00223	0.00175	0.00079
70	0.01229	0.00644	0.00254	0.00191	0.00087
75	0.01356	0.00715	0.00280	0.00212	0.00098
80	0.01500	0.00786	0.00312	0.00228	0.00101
85	0.01636	0.00863	0.00346	0.00242	0.00111
90	0.01780	0.00949	0.00377	0.00261	0.00120
95	0.01924	0.01021	0.00411	0.00277	0.00124
100	0.02070	0.01106	0.00445	0.00297	0.00135
120	0.02644	0.01469	0.00572	0.00369	0.00159
140		0.01849	0.00693	0.00437	0.00190
160		0.02229	0.00820	0.00509	0.00219
180			0.00949	0.00580	0.00249
200			0.01095	0.00651	0.00279
220				0.00735	0.00314
240				0.00811	0.00340
250				0.00849	0.00356
260					0.00373
280					0.00405
300					0.00438
350					0.00518
400					0.00598
440					0.00674
460					0.00706
480					0.00742
500					0.00772
520					0.00814
540					0.00850
560					0.00889
580					0.00929
600					0.00968
620					0.01004
640					0.01036
660					0.01076
680					0.01116
700					0.01156
720					0.01196

T = Minimum static belt tension per rib [N]

Intermediate values can be calculated by linear interpolation.

DESIGN SUPPORT

TECHNICAL TOOLS

FREQUENCY METER / TENSION TESTER **optibelt TT**



The optibelt TT frequency tension tester is an appliance that is used to check the tension of drive belts by means of measuring frequency. Thanks to a compact design, this product offers universal application possibilities in machine construction, in the automotive industry and many other technical applications.

The optibelt TT can even be effortlessly used in difficult-to-reach places so that the tension values of V-belts, ribbed belts and timing belts can be easily and quickly checked.

After start up, the device is immediately ready for obtaining data. The measuring head is held over the belt to be tested (two red LED light points help to position it). The belt is made to vibrate by striking it with a finger or an object. The optibelt TT begins recording data and displays the result in Hertz [Hz]. The condition, colour and type of the belt have no effect upon the measurement.

The tension recommendations can be taken from the Optibelt specifications and the CAP calculation.

$$f = \sqrt{\frac{F_T \cdot 10^6}{4 \cdot m_k \cdot L^2}} \quad [\text{Hz}]$$

with F_T [N], m_k [kg/m] or [g/m] and L [mm]

$$f = \sqrt{\frac{504 \text{ N} \cdot 10^6}{4 \cdot 0.325 \frac{\text{kg}}{\text{m}} \cdot 401^2 \text{ mm}^2}} = 49.1 \text{ Hz}$$

$T \triangleq$ belt tension [N]

$k \triangleq$ meter weight [kg/m]

$L \triangleq$ belt length [mm]

$f \triangleq$ frequency [Hz]

Advantages of optibelt TT

- Two trouble-free measuring methods:
EM: electro magnetic wave
AC: acceleration, integrated
- Usable also for long centre distances by all-time wide frequency range:
AC: 1 - 10 Hz
EM: 6 - 600 Hz
- Easy handling of the measuring head: two red LED points on the belt help to find the correct position
- For hard accessible belt span: measuring head on flexible goose-neck (EM) or with 250 mm cable (AC)
- Safe meter-reading by big display: width 43 mm and height 58 mm, illuminated and colored
- Long running time and environment-friendly by high capacity, rechargeable battery (USB) and changeability
- Chargeable via USB
- No interference in loud and bright environments
- Automatic switch-off function

The optibelt TT:

A guarantee for longer durability of your V-belts, ribbed belts, and timing belts!

DESIGN SUPPORT

TECHNICAL TOOLS

FREQUENCY METER / TENSION TESTER **optibelt TT LINE**



Advantages of optibelt TT DATA

- Comfortable input and selection of belt drive data on touch screen; show own company logo on start display
- Use own belt drive data and general belt set values from optibelt TT database and span length calculation
- Simultaneous display: set, measuring values; simple decision to okay / not okay: select and register tolerances
- Save measurement results and new belt drive data in optibelt TT DATA: Micro SD slot including Micro SD card
- PC synchronisation for database administration with optibelt TT DATA software: USB cable, Micro SD card; optibelt TT DATA update
- Use data from CAP 7.0 in optibelt TT DATA: Send belt drive identification and set values to TT DATA software

Advantages of optibelt TT RFID

- Integrated optibelt TT RFID Reader loads belt drive data directly from the machine: RFID LABEL with data set
- RFID database administration on optibelt TT RFID or, more comfortable on PC: optibelt TT DATA/RFID software
- RFID LABEL data in- and output with optibelt TT RFID or with PC: optional USB RFID Reader Dongle
- RFID LABEL with free print area for address data of machine and user; adhesive backside, on paper rolls
- Print and data input of RFID LABEL with RFID printer: Data e-mailing, RFID LABEL by post
- Easy mounting of RFID LABEL on the machine: 6 mm thick, adhesive and screwable RFID PLATE

Follow soon!

DESIGN HINTS

LENGTH TOLERANCES – INSTALLATION AND MAINTENANCE – TO ISO 9982



Table 20: Length Tolerances

Effective length L_b [mm]	Profile PH	Profile PJ	Profile PK	Profile PL	Profile PM
	Tolerance [mm]	Tolerance [mm]	Tolerance [mm]	Tolerance [mm]	Tolerance [mm]
> 200 ≤ 500	+ 4 – 8	+ 4 – 8	+ 4 – 8		
> 500 ≤ 750	+ 5 – 10	+ 5 – 10	+ 5 – 10		
> 750 ≤ 1000	+ 6 – 12	+ 6 – 12	+ 6 – 12	+ 6 – 12	
> 1000 ≤ 1500	+ 8 – 16	+ 8 – 16	+ 8 – 16	+ 8 – 16	
> 1500 ≤ 2000	+ 10 – 20	+ 10 – 20	+ 10 – 20	+ 10 – 20	
> 2000 ≤ 3000	+ 12 – 24	+ 12 – 24	+ 12 – 24	+ 12 – 24	+ 12 – 24
> 3000 ≤ 4000				+ 15 – 30	+ 15 – 30
> 4000 ≤ 6000				+ 20 – 40	+ 20 – 40

Installation and Maintenance

Geometrically correct designing and power rating of drives with optibelt RB ribbed belts ensures long belt life and a high degree of operating safety.

Since practice has shown that premature failure can very often be traced to faulty installation or maintenance, we recommend that you follow the installation and maintenance instructions listed below.

- **Safety**

Before commencing any maintenance work, ensure that all machine components are safely positioned and cannot be altered whilst the work is in progress. It is also important that the manufacturer's safety instructions are carefully followed.

- **Pulleys**

The grooves must be in good condition, free from scoring, sharp edges or rust and all dimensions should conform to the relevant standard.

- **Alignment**

Shafts and pulleys should be correctly aligned prior to belt installation. We recommend a maximum tolerance of 0.5° in both planes.

- **Installation of ribbed belts**

The centre distance should be reduced prior to the installation of ribbed belts so that they may be fitted in the grooves without undue force. Forcing ribbed belts over the pulley flanges with a tyre lever, screwdriver or the like, must be avoided as the damage this causes to the ribs and low-stretch tension members is often not visible.

- **Ribbed belt tension**

Once the calculated axial force has been applied, the tension of the ribbed belts should be checked using our tension gauges and the methods described on pages 48 to 51. The belt should be observed regularly during the first few hours of service. Experience has shown that the belt will need retensioning after between 0.5 and 4 hours at full load to take up the initial belt stretch.

- **Tension/guide idlers**

Where possible, the use of tension and guide idlers should be avoided. If this is not possible, refer to the notes on pages 33 to 34 of this manual and follow any instructions given.

- **Maintenance**

It is recommended that ribbed belt drives should be regularly inspected. This should include checking and, if necessary, correcting the tension. Suitable guards must be provided to prevent the intrusion of foreign bodies such as stones, swarf or other material between the pulley and the belt. optibelt RB ribbed belts do not require any special care. Belt dressing (belt wax and spray) should not be used under any circumstances.

DESIGN HINTS

RIBBED BELT WIDTHS



Table 21

Number of ribs z	Profile PH [mm]	Profile PJ [mm]	Profile PK [mm]	Profile PL [mm]	Profile PM [mm]
2	3.20	4.68	7.12	9.40	18.80
3	4.80	7.02	10.68	14.10	28.20
4	6.40	9.36	14.24	18.80	37.60
5	8.00	11.70	17.80	23.50	47.00
6	9.60	14.04	21.36	28.20	56.40
7	11.20	16.38	24.92	32.90	65.80
8	12.80	18.72	28.48	37.60	75.20
9	14.40	21.06	32.04	42.30	84.60
10	16.00	23.40	35.60	47.00	94.00
11	17.60	25.74	39.16	51.70	103.40
12	19.20	28.08	42.72	56.40	112.80
13	20.80	30.42	46.28	61.10	122.20
14	22.40	32.76	49.84	65.80	131.60
15	24.00	35.10	53.40	70.50	141.00
16	25.60	37.44	56.96	75.20	150.40
17	27.20	39.78	60.52	79.90	159.80
18	28.80	42.12	64.08	84.60	169.20
19	30.40	44.46	67.64	89.30	178.60
20	32.00	46.80	71.20	94.00	188.00
21	33.60	49.14	74.76	98.70	197.40
22	35.20	51.48	78.32	103.40	206.80
23	36.80	53.82	81.88	108.10	216.20
24	38.40	56.16	85.44	112.80	225.60
25	40.00	58.50	89.00	117.50	235.00
26	41.60	60.84	92.56	122.20	244.40
27	43.20	63.18	96.12	126.90	253.80
28	44.80	65.52	99.68	131.60	263.20
29	46.40	67.86	103.24	136.30	272.60
30	48.00	70.20	106.80	141.00	282.00

Ribbed belts with more than 30 ribs should be divided.
A space of one rib should be maintained between two ribbed belts.

DESIGN HINTS

PROBLEMS – CAUSES – REMEDIES





Problem	Causes	Remedies
<p>Excessive wear of ribs</p> 	<p>Belt tension too low</p> <p>Ingress of foreign body during running</p> <p>Pulley misalignment</p> <p>Faulty pulleys</p> <p>Wrong belt or pulley profile</p>	<p>Check belt tension and correct</p> <p>Fit an effective guard</p> <p>Re-align pulleys</p> <p>Re-machine or replace pulleys</p> <p>Belt and pulley profiles must be correctly matched</p>
<p>Ribbed belt breakage shortly after fitting (belt torn)</p> 	<p>Belt rubbing or catching on protruding parts</p> <p>Drive stalled</p> <p>Drive overloaded</p> <p>Contamination with oil, grease or chemicals</p>	<p>Remove any parts that are in the way; re-align drive</p> <p>Ascertain cause and put it right</p> <p>Check drive conditions and re-dimension</p> <p>Protect drive from environmental influences</p>
<p>Rib breakage and cracks (brittleness)</p> 	<p>Outside idler pulley in use whose position and size is not as recommended</p> <p>Pulley diameter too small</p> <p>Excessive exposure to heat</p> <p>Excessive exposure to cold</p> <p>Abnormal belt slip</p> <p>Chemical influences</p>	<p>Follow Optibelt recommendations, e.g. increase pulley size; replace with inside idler on the slack side of the drive</p> <p>Re-design using recommended minimum pulley diameters</p> <p>Remove or shield from heat source; ensure good ventilation</p> <p>Warm belt before start up</p> <p>Retention drive according to installation instructions; check drive design and modify if necessary</p> <p>Shield drive</p>

DESIGN HINTS

PROBLEMS – CAUSES – REMEDIES



Problem	Causes	Remedies	
Severe belt vibration	Drive undersized Drive centre distance significantly longer than recommended High shock loading Belt tension too low Unbalanced pulleys	Check drive design and modify if necessary Shorten centres, use an inside idler on the belt slack side Use an inside idler on the slack side Correct belt tension Balance pulleys	
Ribbed belts cannot be retensioned	Insufficient allowance for centre distance in drive design Excessive stretch caused by overloaded drive Incorrect belt length	Modify drive to allow for the Optibelt recommended take-up Carry out drive calculation and re-design Use a shorter belt	
	Excessive running noise	Poor pulley alignment Belt tension too low or too high Drive overloaded	Align pulleys Check belt tension Check drive design and modify if necessary
Ribbed belt swelling and softening	Contamination with oil, grease or chemicals	Protect drive from source of contamination Clean pulleys with cleaning solvent or benzene before fitting new ribbed belts!	
			

Please contact our Applications Engineering Department in the case of other faults. Please give us as much technical information as possible to assist us with replying to your query.

DESIGN HINTS

ADDITIONAL RANGE



optibelt TT FREQUENCY METER

Optibelt presents the new generation of TT frequency meter – indispensable for quickly and accurately determining the correct drive belt tension. Now even easier to use and with additional data processing options.

Advantages

- Measuring range from 1 Hz to 600 Hz
- No interference in loud and bright environments
- Display of the last measurement value
- Chargeable via USB



optibelt LASER POINTER II

An indispensable aid for belt drives

The user-friendly optibelt LASER POINTER II is a device of proven value, especially for everyday use. The optibelt LASER POINTER II makes it easier to align belt drives. It also helps to determine the most common causes of drive failures:

- Axial misalignment of the pulley
- Horizontal angular misalignment
- Vertical angular misalignment



OPTIBELT PULLEY GROOVE GAUGES

Belts and pulleys can be quickly and effortlessly identified with these groove gauges. They also enable pulley groove edges to be tested for angular deviation and wear.



DATA SHEET FOR DRIVE CALCULATION/CHECKING



Company _____
 Street/PO Box _____
 Postcode/zip code; town _____
 Administrator _____
 Department _____ Date _____
 Tel. () _____ Email _____

For trials New drive
 For pilot series Existing drive
 For production series Requirement _____ belts/year

Fitted with:

Pieces	Effective length	Profile	Number of ribs	Manufacturer

Prime Mover

Type (e.g. electric motor, diesel engine 3 cyl.) _____
 Size of starting load (e.g. starting load = 1.8 normal load) _____
 Method of starting (e.g. star delta) _____
 Operation hours per day _____
 Number of starts _____ per hour per day
 Rotational reverses _____ per minute per hour
 Power: P normal _____ kW
 P maximal _____ kW
 or max. torque _____ Nm at n_1 _____ rpm
 Speed of driver pulley n_1 _____ rpm
 Position of shafts: horizontal vertical
 angled <) _____ °
 Maximum allowed static shaft loading $S_{a\max}$ _____ N
 Effective or outside diameter of driver pulley:
 d_{b1} _____ mm
 $d_{b1\min}$ _____ mm
 $d_{b1\max}$ _____ mm
 Pulley face width $b_{2\max}$ _____ mm

Driven Machine

Type (e.g. lathe, compressor) _____
 Start: loaded unloaded
 Nature of load: constant pulsating
 shock
 Load: P normal _____ kW
 P maximal _____ kW
 or max. torque _____ Nm at n_2 _____ rpm
 Speed of driven pulley n_2 _____ rpm
 $n_{2\min}$ _____ rpm
 $n_{2\max}$ _____ rpm
 Maximum allowable static shaft loading $S_{a\max}$ _____ N
 Effective or outside diameter of driven pulley:
 d_{b2} _____ mm
 $d_{b2\min}$ _____ mm
 $d_{b2\max}$ _____ mm
 Pulley face width $b_{2\max}$ _____ mm

Speed ratio i _____
 Drive centre distance a _____ mm
 Tension/guide idler pulley: inside
 outside
 d_b _____ mm ribbed pulley
 d_a _____ mm flat pulley

i_{\min} _____ i_{\max} _____
 a_{\min} _____ mm a_{\max} _____ mm
 in drive slack side
 in drive tight side
 moveable (e.g. spring loaded) _____
 fixed

Drive Conditions: Ambient temperature

Exposure to oil
 water
 acid
 dust

_____ °C/F min.
 _____ °C/F max.
 (e.g. oil mist, droplets) _____
 (e.g. spray) _____
 (type, concentration, temperature) _____
 (type) _____

Special conditions: Where the drive has inside or outside idler pulleys, three or more driven pulleys or counter-rotating shafts then a drawing or any other relevant information should be submitted.

